

## PART LIST

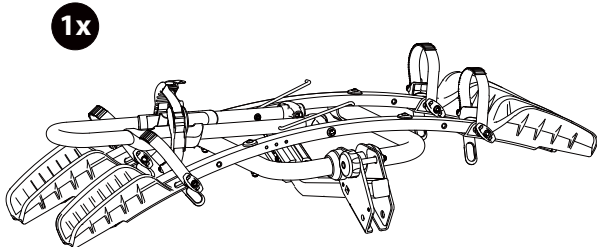

1x

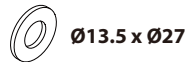

1x

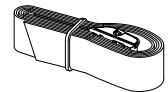

1x

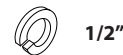

1x

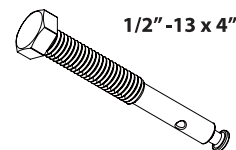

1x



2x



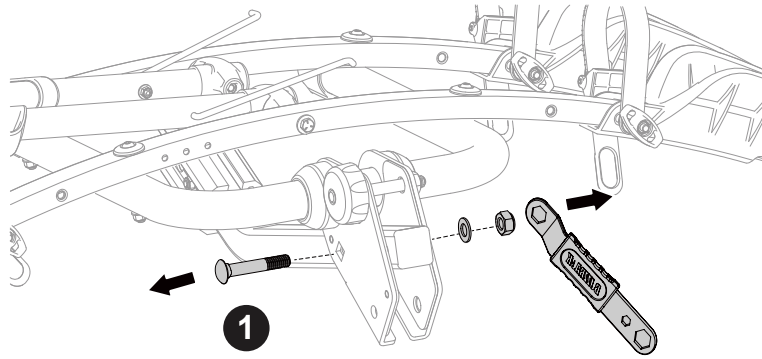
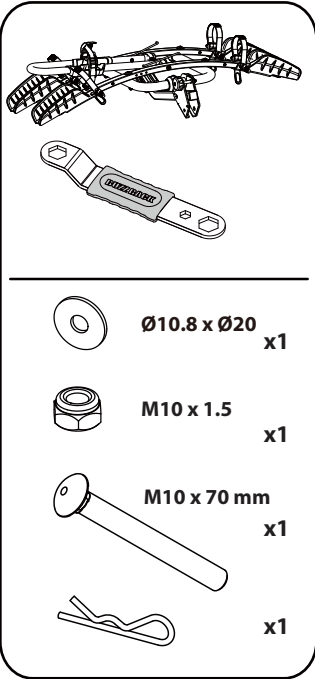

1

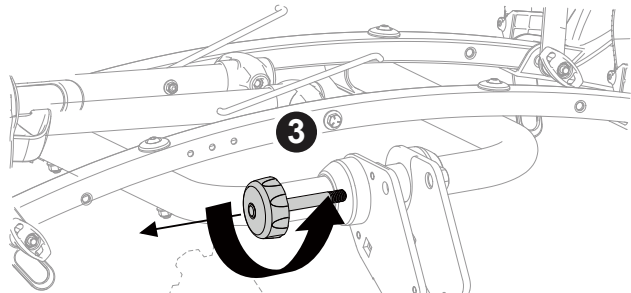

3

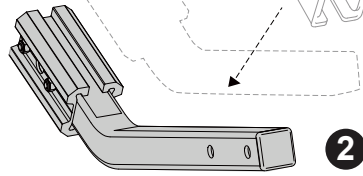

2

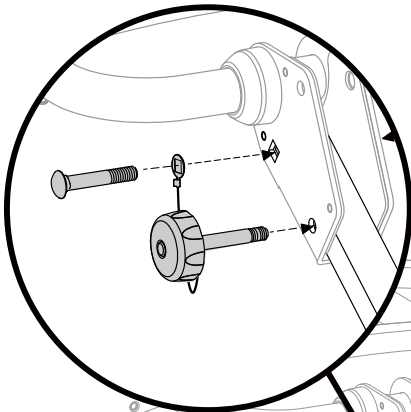

5

6

4

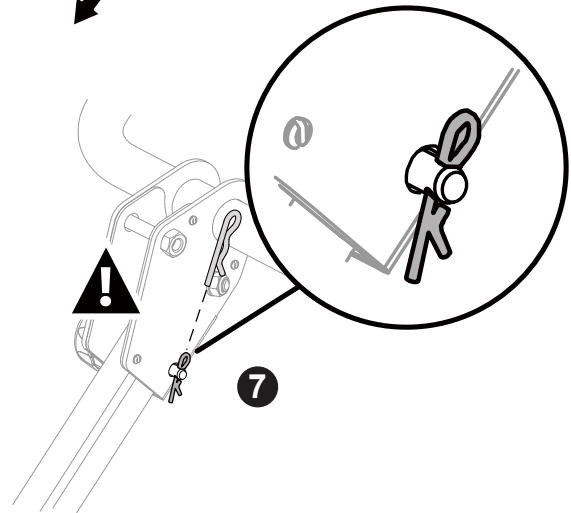

7

**OK**



~~**OK**~~

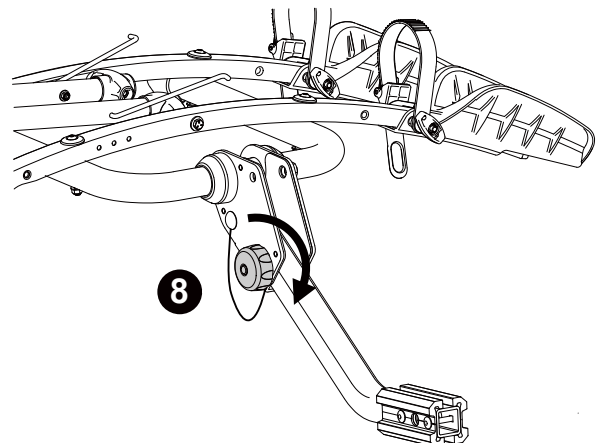
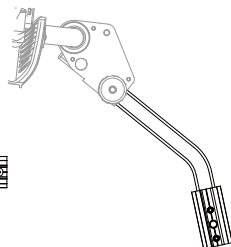
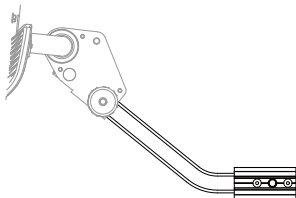



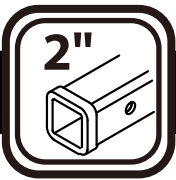

8

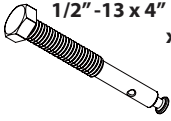

-  **SUZUKI**

---

-  **1/2" -13 x 4"** x1
-  **Ø13.5 x Ø27** x1
-  **1/2"** x1
-  x1

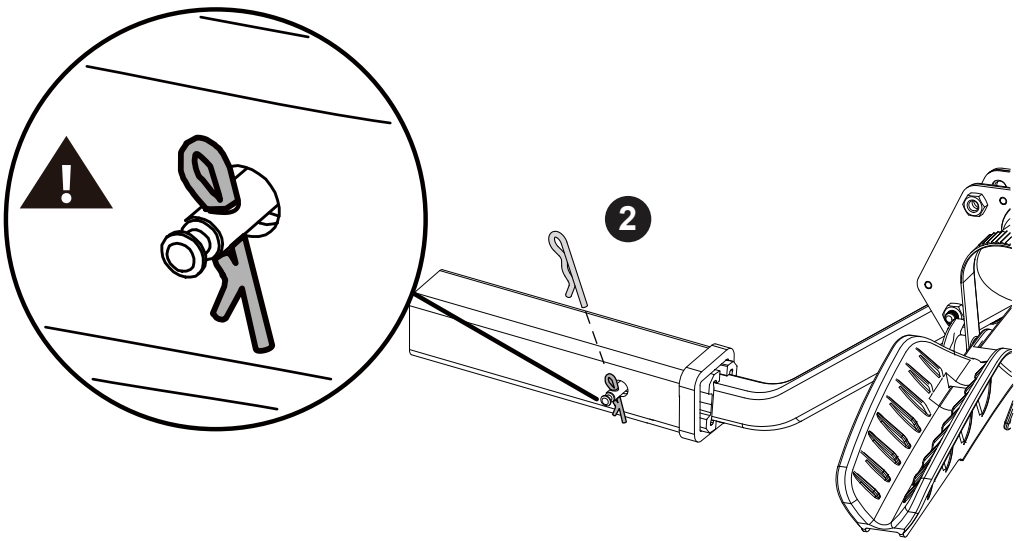
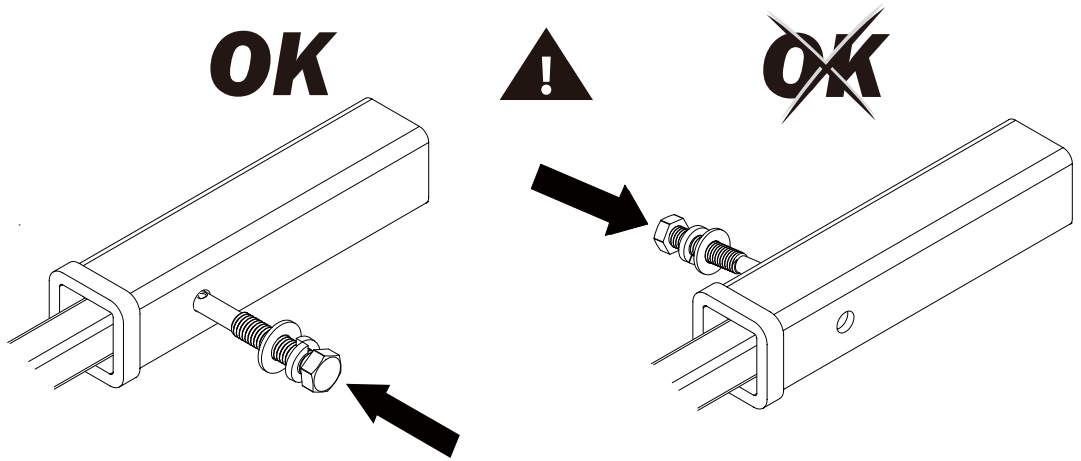
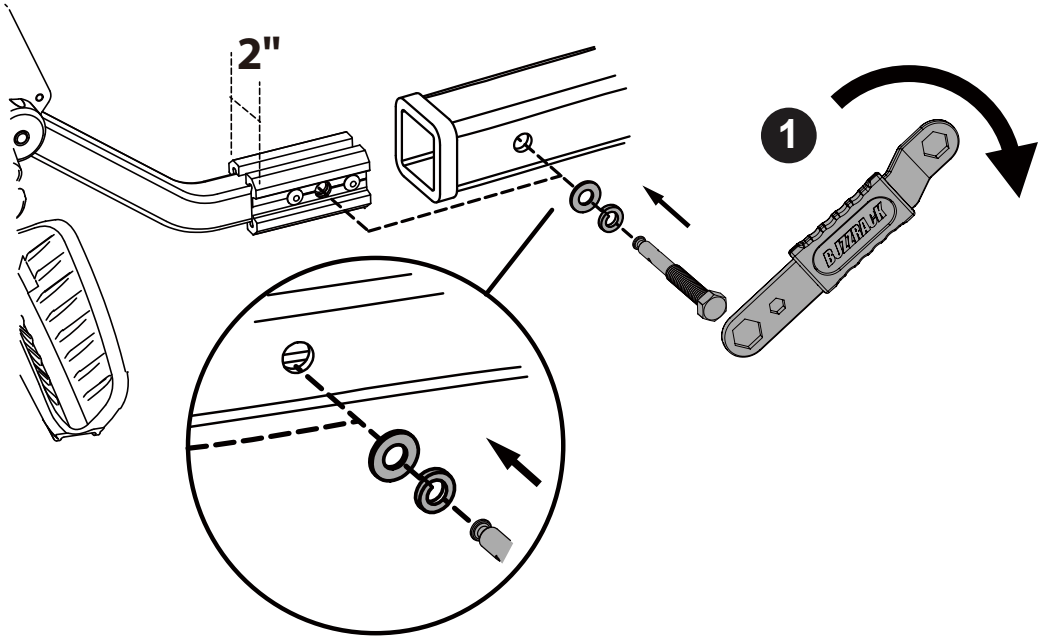

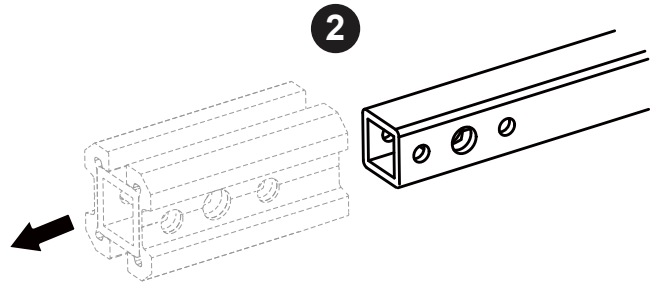
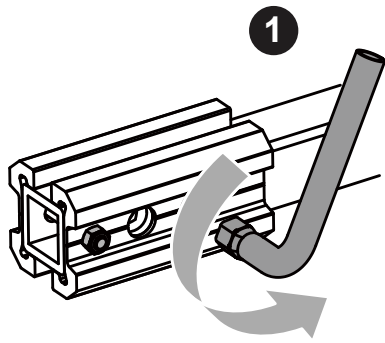

1 1/4"

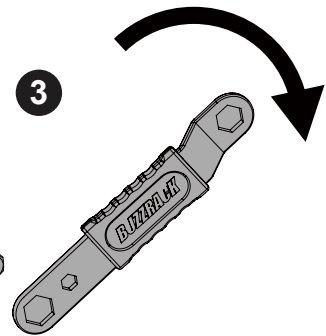
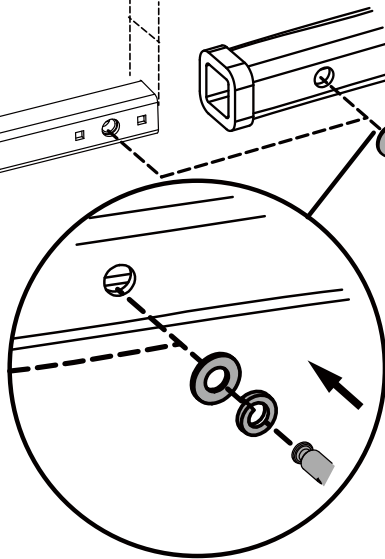

**OK**



~~**OK**~~

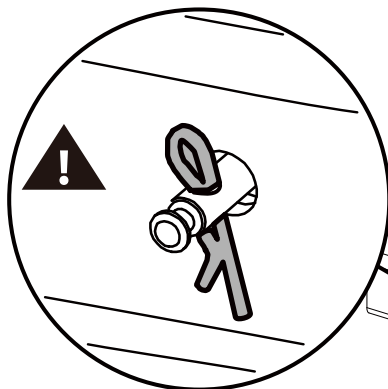
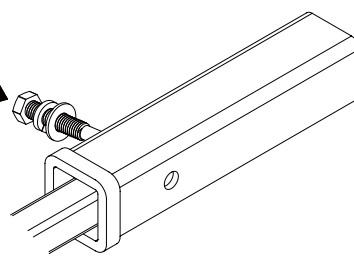
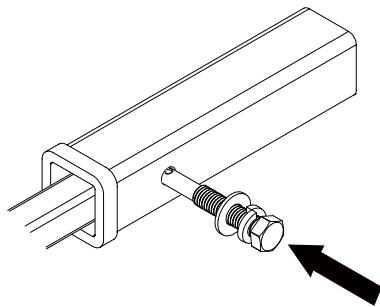

4

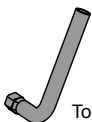
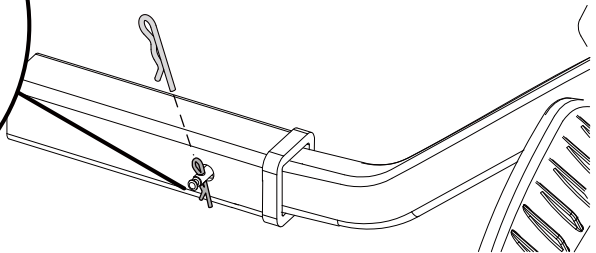

Tool Not Included

**4**

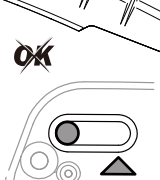
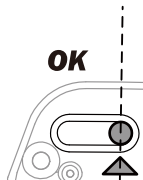
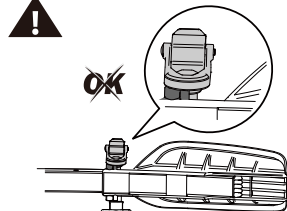
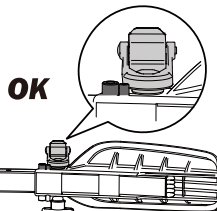
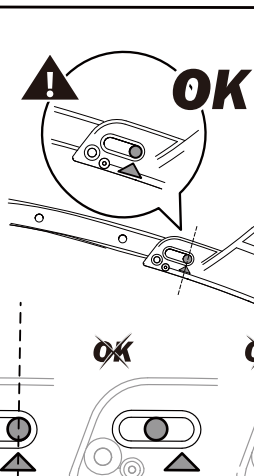
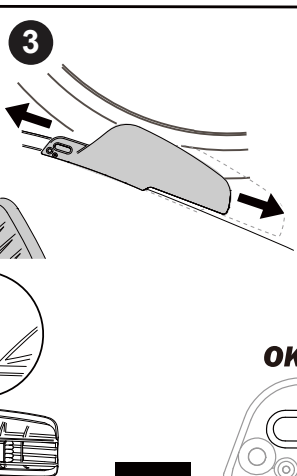
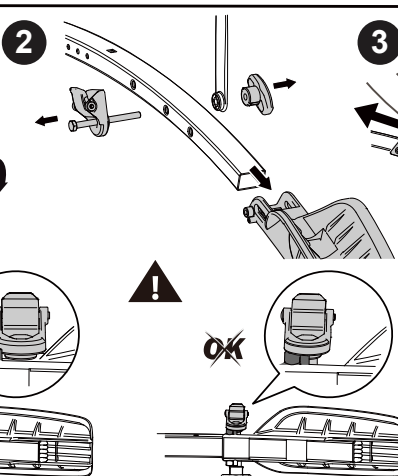
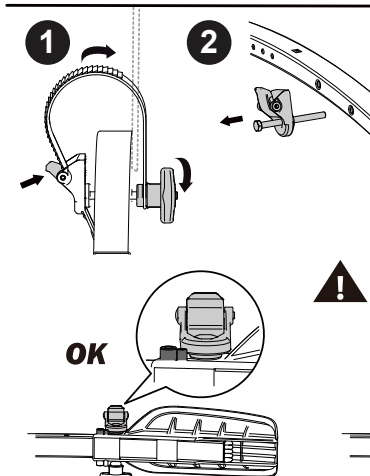
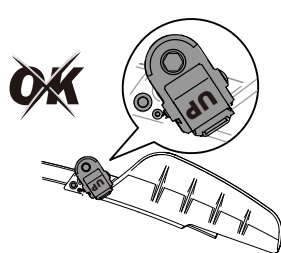
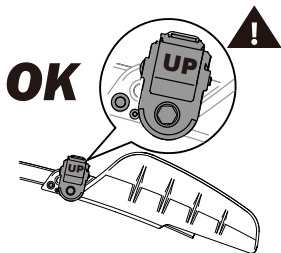
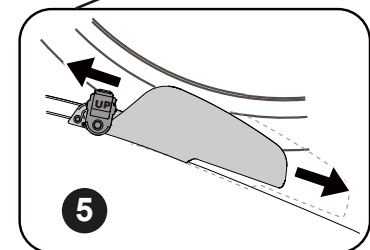
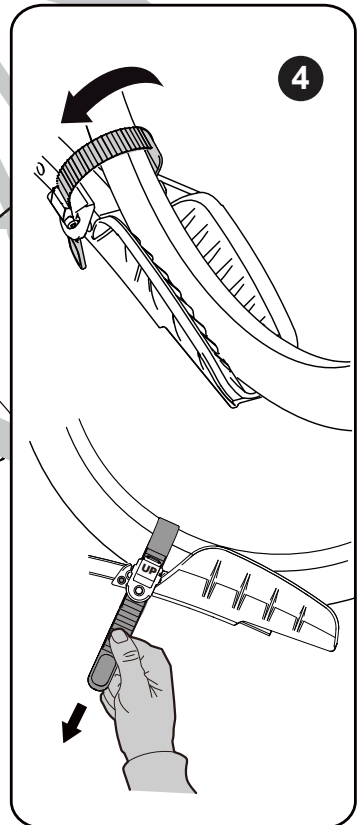
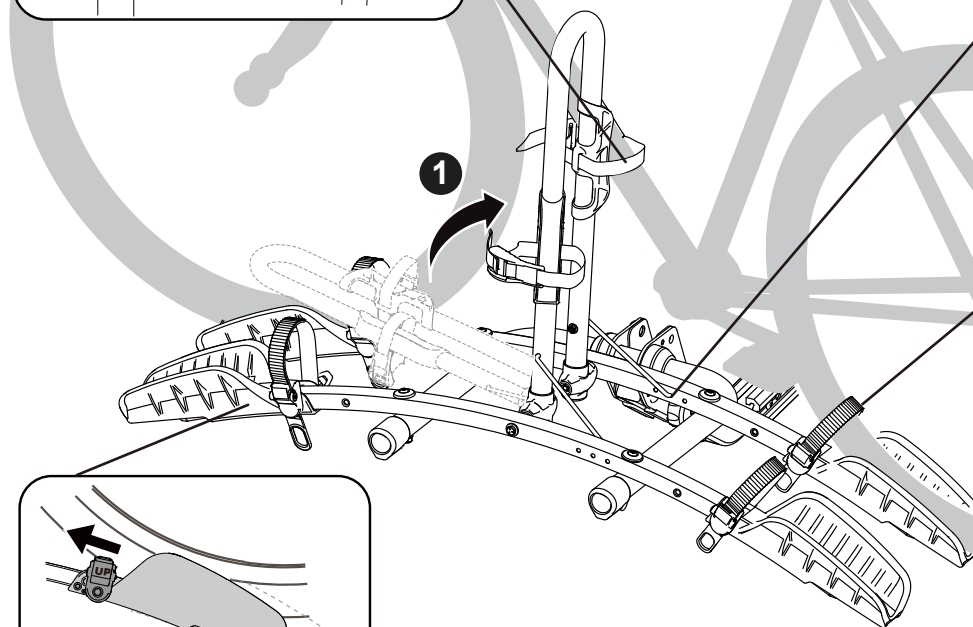
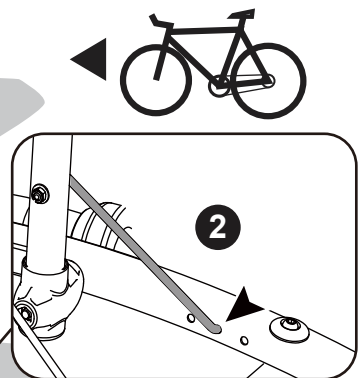
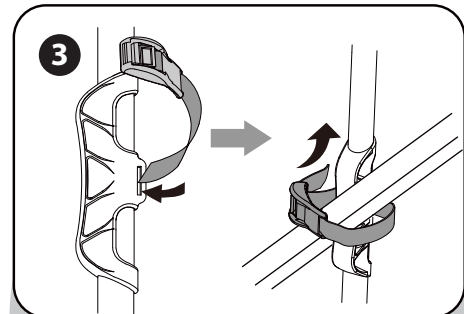
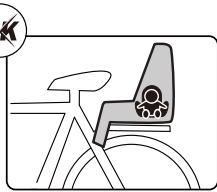
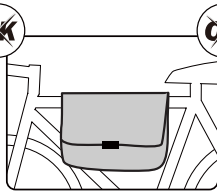
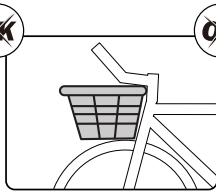
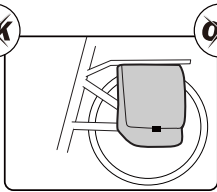
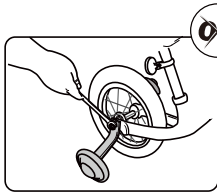

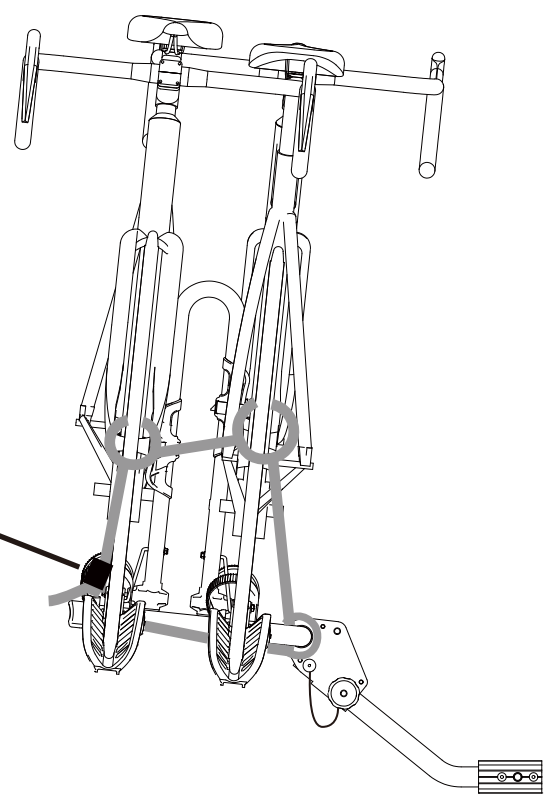
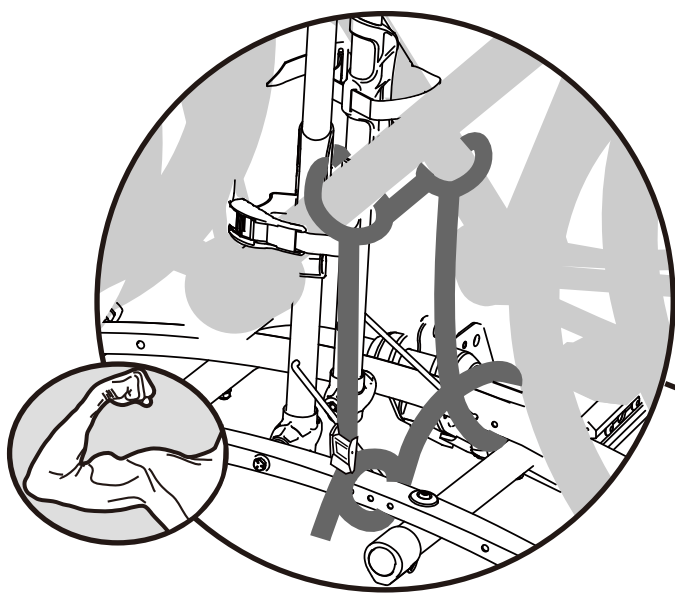
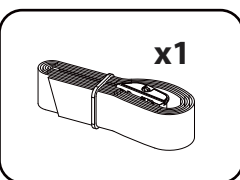
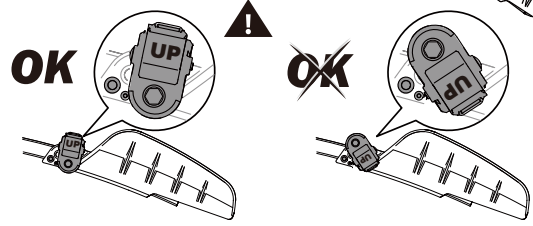
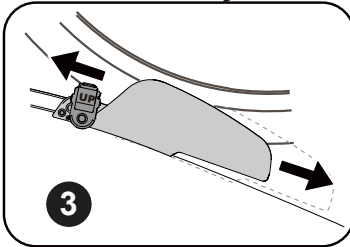
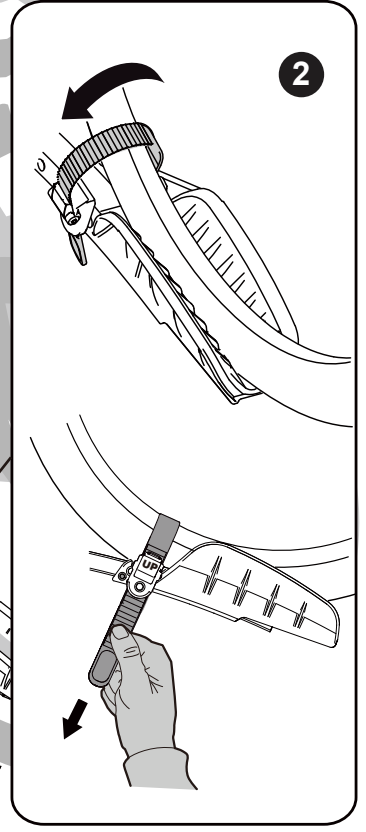
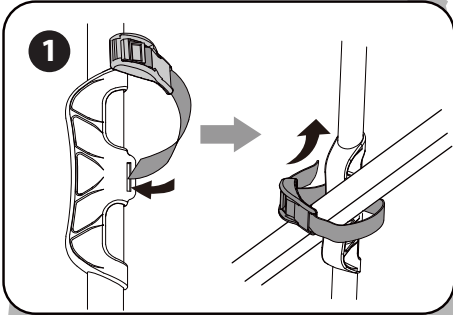

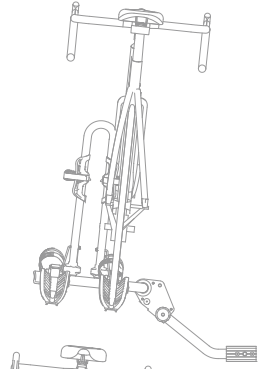

**OK**

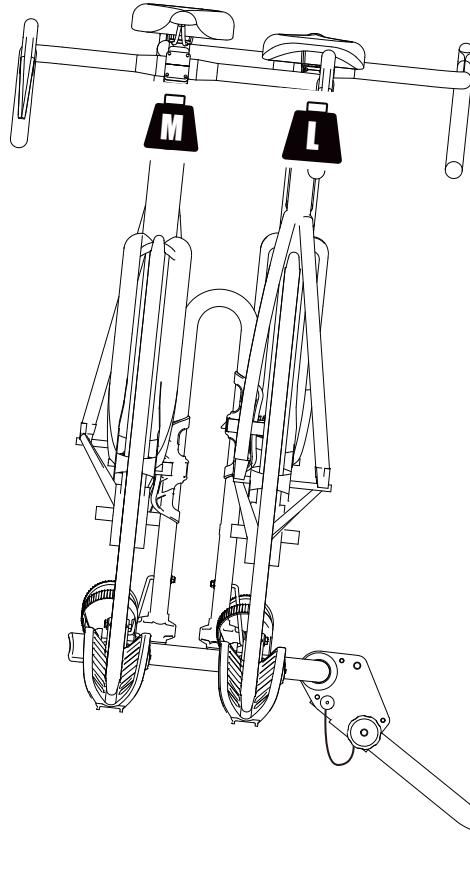
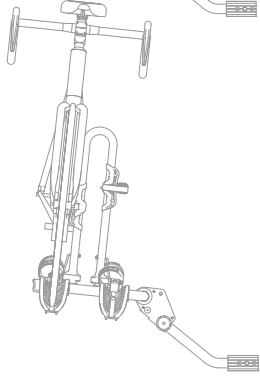

~~**OK**~~



**1**  = 1x15kg MAX

**2**  = 2x15kg MAX

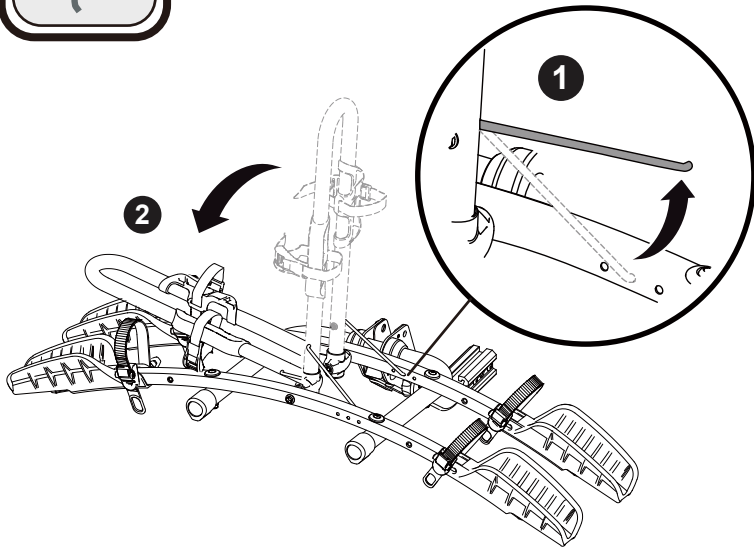

**2**

**1**

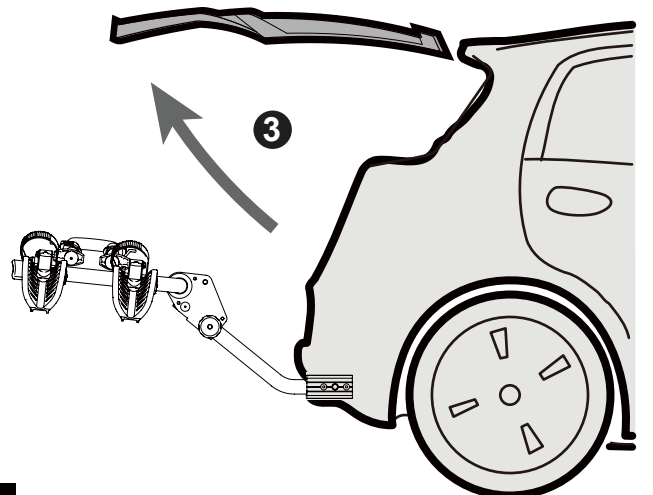

**3**

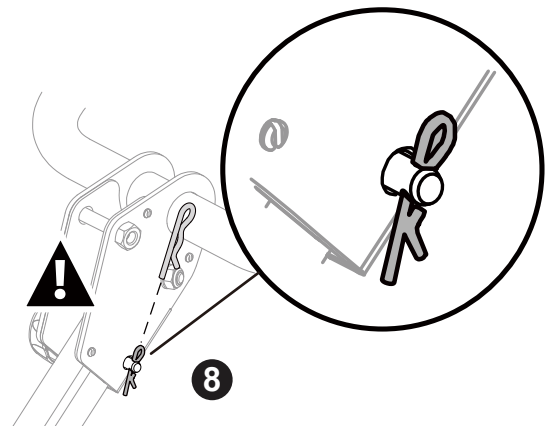
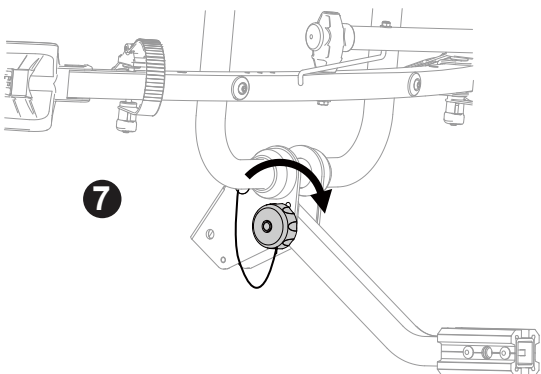
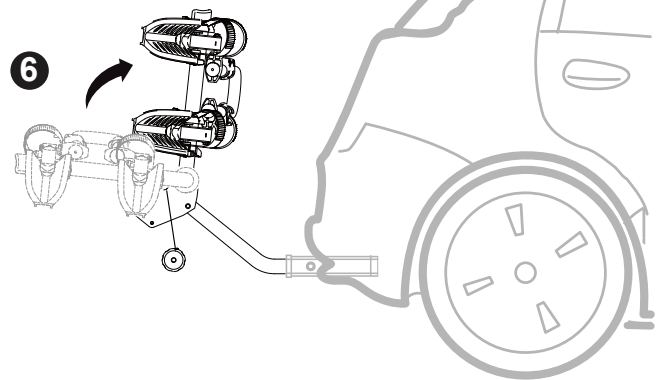
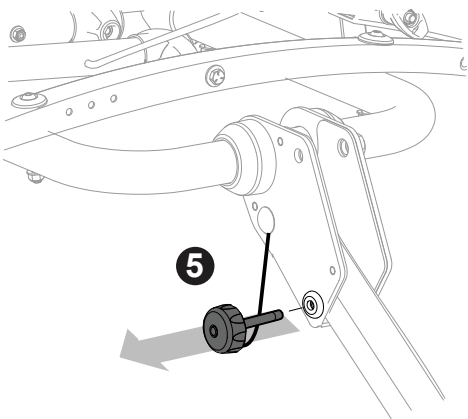
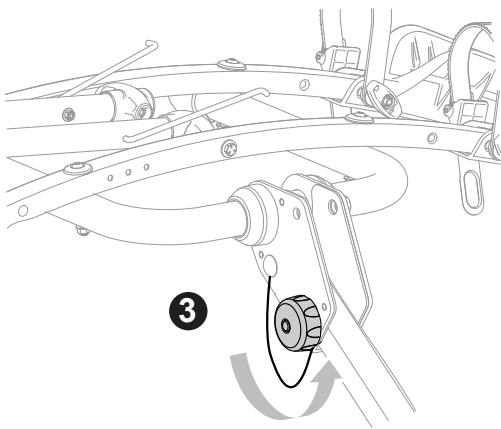
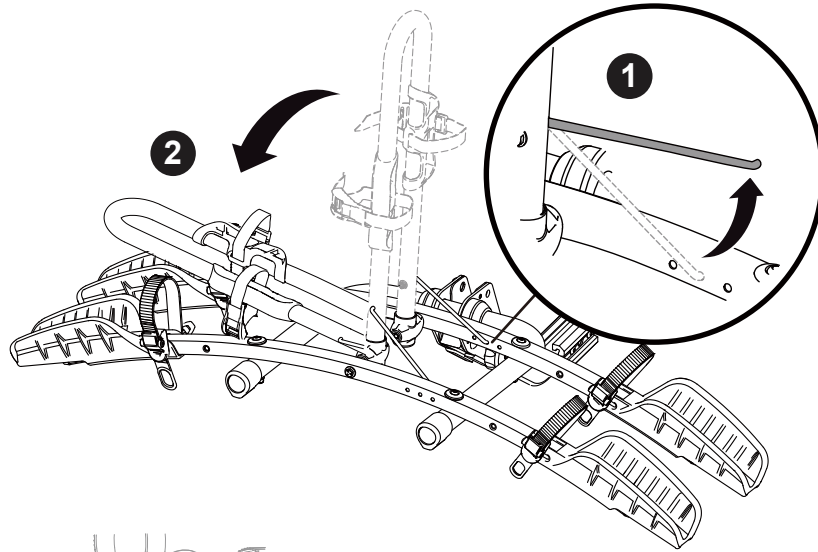
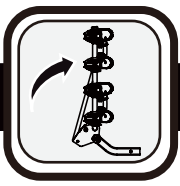



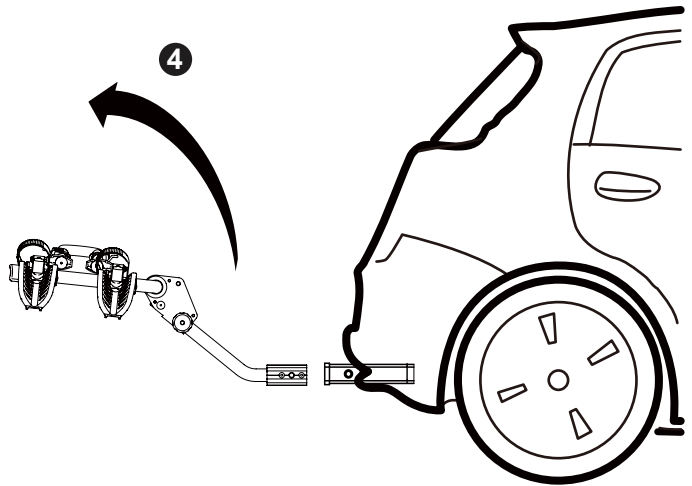
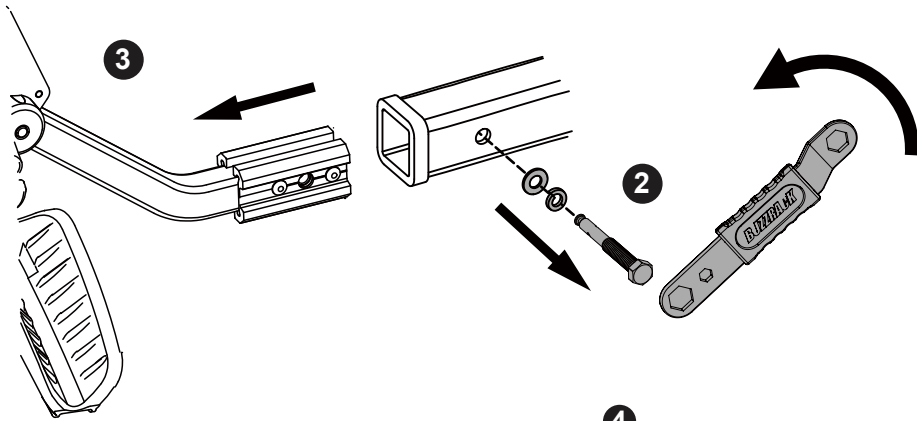
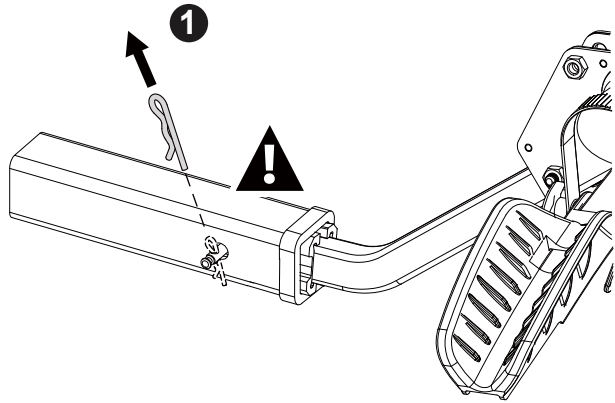
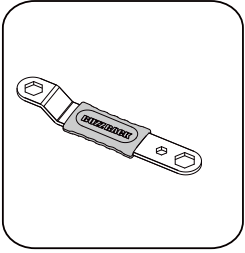

**GENERAL REMARKS**

01. Please read and observe the instructions carefully before you use the product, and keep them in a safe place for future use. Check the part list after opening the package. Make sure that all the parts are fully assembled according to the instruction before fitting it on your car.
02. The user is responsible for assembly and installation of this product, and the manufacturer disclaims any liability due to improper fitting or use of the product.
03. Failure to properly install this bike carrier and/or the bikes may cause damage to the vehicle and/or the bikes, and may result in personal injury.
04. Do not use this product for purposes other than those for which it is designed. Do not modify any components of the product. Remove the carrier if not in use.
05. Do not use the carrier to carry more bikes than recommended. The weight of each bike cannot exceed 15kg/ 33lbs.
06. Do not install the bike carrier on trailers, campers, or RVs.
07. This bike rack is not intended for transporting tandem, or recumbent bicycles.
08. Do not transport bicycles with attached baby seats, panniers, wheel covers, full bike covers or motors.
09. BuzzyBee H2 and H3 fits 1 1/4" and 2" hitch receivers. BuzzyBee H4 fits 2" receivers only.
10. Fits 1 1/4" (3.2 cm) and 2" (5.1 cm) hitch receivers.

**SAFE AND PROPER USE**

01. Always use the safety strap to attach the bikes to the bike carrier.
02. Check that the hitch tube is properly fastened to the hitch receiver on the car.
03. Check if the distance from the exhaust pipe to the bicycle tires is safe for your bicycles or the straps of the carrier. The heat of the exhaust could damage the bike or bicycle racks.
04. If your vehicle is equipped with an automatic tailgate opening system, disable this function when using the bike carrier, and open the tailgate manually.
05. When loading the bicycles, remove all loose parts and accessories from bicycles (toolbars, baby carriers, pumps, etc.)
06. Always position the biggest/heaviest bike first and closest to the car, and then position the smaller bike after that.
07. The user is responsible for periodically verifying that all hardware, straps, knobs, hubs are securely tightened for safety purposes.
08. You might have to use extra protections to protect the bikes and the tailgate from scratches.
09. Do not open the gate with the bikes installed on the carrier.
10. The locks used on this rack are theft deterrent.

**ROAD SAFETY**

01. The bicycle rack increases the vehicle's length, and the bicycles may increase its width and height. Be aware of this when passing through narrow or low clearance spaces and when reversing. Any loads exceeding the indicated dimensions must nevertheless respect existing regulations and be properly strapped down.
02. The load of rack and bicycles will affect driving. Do not exceed the speed limit, and do not drive faster than 120 km/h (75 mph).
03. Drive slowly over speed bumps. Respect the speed limit, and adapt your speed to the condition of the road.
04. Off-road driving is not recommended and could result in damage to your vehicle, hitch receiver, bike carrier, or your bikes.
05. If you hit a bump or a hole in the road, stop your vehicle and inspect the bikes and the carrier. If you notice anything wrong, remove the bikes and do not use the bike carrier.
06. Make sure there is a safe distance between the bikes and the ground, especially when entering a driveway.

**MAINTAINING YOUR BICYCLE RACK**

01. Periodically inspect the product for signs of wear, corrosion, and fatigue.
02. Do not use the carrier with defective parts, contact the dealer to replace them before using it again.
03. Remove the product before entering an automatic car wash.
04. To keep your product in the best condition, it is recommended to remove the product from the car when not in use. Please be advised that this product is not designed to resist extreme weather conditions, especially sea-coast air.
05. Lubricate the bolts in order to avoid corrosion.

**GENERALITES**

01. Lire attentivement les instructions et les conserver pour une utilisation ultérieure. Vérifier la liste des pièces à l'ouverture de la boîte. S'assurer que le produit est assemblé selon les instructions avant de le monter sur le véhicule.
02. L'utilisateur est entièrement responsable de l'assemblage, de l'installation et de l'utilisation du produit. Le fabricant et le distributeur ne pourront être tenus responsables de réclamations suite à une utilisation inadéquate du produit.
03. Une mauvaise installation du produit ou des vélos peut entraîner des dommages matériels au véhicule ainsi qu'aux vélos et dans le pire cas des dommages corporels.
04. Ne pas utiliser le produit à d'autres fins que celles pour lesquelles il a été conçu. Ne pas modifier de composants du produit. Retirer le produit lorsque vous ne l'utilisez pas.
05. Ne pas transporter plus de vélos que la quantité recommandée (maximum de 15 kg/33 lb par vélo) sur le porte-vélo.
06. Ne pas installer ce produit sur une remorque, une auto-caravane (camping-car) ou une maison mobile.
07. Le porte vélos n'est pas prévu pour le transport de tandems, ou vélos à position allongée.
08. Ne pas transporter de bicyclettes munies d'un siège de bébé, de sacoches, de housses de roues, d'une housse de vélo complète ou d'un moteur.
09. BuzzyBee H2 et H3 sont conçus pour être montés sur des attelages de 1 1/4" et 2". BuzzyBee H4 se monte uniquement sur attelages de 2".
10. Conçu pour être monté sur des attelages de 1 1/4" et 2".

**UTILISATION DU PRODUIT**

01. Toujours utiliser les sangles de sécurité si elle est fourni dans le package fournies pour attacher les vélos au porte-vélo.
02. Vérifier que le tube de fixation à l'attelage est correctement fixé à celui-ci.
03. Vérifier la proximité entre la sortie de l'échappement et les pneus des vélos ou les sangles d'attache. La chaleur du pot d'échappement pourrait endommager les vélos ou le porte-vélos.
04. Si votre véhicule est équipé d'une ouverture automatique du hayon, désactiver le système et ouvrir le hayon manuellement.
05. Avant l'utilisation, retirer des vélos tous les éléments qui pourraient se détacher (pompe, sacoches, outils, etc) ainsi que les sièges à bébé.
06. Toujours positionner le vélo le plus lourd ou le plus gros dans la première position (celle proche du véhicule)
07. L'utilisateur a la responsabilité de vérifier périodiquement que tous les éléments de serrage ou de montage sont bien serrés pour une sécurité optimale.
08. Il est possible que vous soyez obligé d'utiliser des éléments supplémentaires pour empêcher les vélos de s'endommager ou d'endommager le hayon de véhicule.
09. Ne pas ouvrir le coffre lorsque les porte-vélos sont installés sur le porte-vélos.
10. Les serrures ont une fonction du vol de dissuasion.

**SECURITE ROUTIERE**

01. Le porte vélos augmente la longueur du véhicule et les vélos peuvent modifier la largeur et la hauteur véhicule. Attention en cas de passage étroit et délicat ou en cas de marche arrière. Les charges débordant le dispositif de portage doivent remplir les prescriptions de la réglementation en vigueur et être convenablement sangle.
02. Le chargement modifie les conditions de conduite et de manoeuvrabilité. Toujours respecter les limites de vitesse sans jamais dépasser 120 km/h (75 mph) si la vitesse limite y est supérieure.
03. Conduire lentement au passage des ralentisseurs. Adapter la conduite aux conditions de la route.
04. La conduite hors route n'est pas recommandée: cela pourrait endommager le véhicule, l'attelage, le porte-vélo, ou les vélos.
05. Si, par accident, vous passez sur une bosse ou un trou, arrêter le véhicule et vérifier les vélos et le porte-vélo. Si vous remarquez quelque chose d'anormal sur le produit, retirer les vélos et le produit et demander conseil à votre magasin.
06. S'assurer que la distance entre les vélos et le sol est suffisante pour éviter tout contact surtout en rentrant dans un garage ou un stationnement.

**MAINTENANCE DU PRODUIT**

01. Examiner le produit régulièrement afin de détecter tout signe d'usure, de corrosion ou de fatigue.
02. Ne pas utiliser le produit si vous constatez que des pièces sont endommagées. Communiquer avec le revendeur.
03. Retirer le produit dans les lave-autos automatiques.
04. Il est recommandé de ne pas laisser le produit sur le véhicule quand il n'est pas utilisé. Ce produit n'est pas conçu pour résister à des environnements extrêmes, comme par exemple l'air salin.
05. Lubrifier régulièrement les vis et boulons pour éviter toute corrosion.

### GENERALIDADES

- 01. Antes de usar el producto, usted debe leer obligatoriamente la nota de advertencias y las instrucciones de montaje, las que deben conservarse para utilizations futuras y para un uso seguro. Deben leerse y respetarse hasta en los más pequeños detalles.
- 02. El usuario es responsable del montaje y la instalación de este producto, y el fabricante se exime de cualquier responsabilidad debido a la instalación o uso inadecuado de portabicicletas.
- 03. Si no se instala correctamente este portabicicleta y / o las bicicletas se puede causar daños al vehículo y / o a las bicicletas, y puede resultar en lesiones personales.
- 04. No use este producto para fines distintos de los que fue diseñado. No modifique los componentes del portabicicleta. Retire el producto cuando no se usa.
- 05. No utilice el portador para llevar a más bicicletas de lo recomendado. El peso de cada bicicleta no puede exceder 15kg/33lbs.
- 06. No instale en remolques o casas rodantes.
- 07. El portabicicleta no está diseñado para el transporte de tandems.
- 08. No transporte bicicletas con asientos para bebés, cestas, guardabarros, cubrebicicletas completos o motores.
- 09. BuzzyBee H2 y H3 encaja a receptores de enganche de 1 1/4 "y 2". BuzzyBee H4 encaja sólo a receptores de 2".
- 10. Se encaja a receptores de enganche de 1 1/4 "(3,2 cm) y 2" (5,1 cm).

### USO SEGURO Y ADECUADO

- 01. Utilice siempre los cinturones de seguridad proporcionados para fijar las bicicletas en el portabicicleta con seguridad.
- 02. Compruebe que el tubo de enganche esté bien sujetado al receptor de enganche en el coche.
- 03. No deje que los neumáticos de las bicicletas cuelguen cerca del escape del vehículo.
- 04. Si su vehículo está equipado con un sistema de portón trasero de apertura automática, deshabilite esta función cuando se usa el portabicicleta, y abre el portón manualmente.
- 05. Al cargar las bicicletas, quite todas las piezas sueltas y accesorios de bicicletas (barras de herramientas, porta bebés, bombas, etc.)
- 06. Siempre coloque la bicicleta más grande / pesada primero cerca del vehículo, y luego las más pequeñas
- 07. El usuario es responsable de verificar periódicamente que todo el hardware, las correas, los botones, los centros estén bien apretados por motivos de seguridad.
- 08. Es posible que tenga que usar protecciones adicionales para proteger las bicicletas y el portón trasero de rasguños.
- 09. No abra la puerta con las bicicletas instaladas en el portador.
- 10. Las cerraduras usadas en este rack son para disuadir a ladrones

### SEGURIDAD EN LA RUTA Y CONDUCCIÓN

- 01. El portabicicletas puede aumentar el largo y el ancho del vehículo. Tome precauciones en caso de pasar por lugares estrechos o peligrosos o en caso de conducir en reversa. Las cargas que sobrepasan la superficie de carga deben cumplir con las prescripciones de la reglamentación en vigor y ser dispuestas correctamente.
- 02. La carga de la portadora y bicicletas afectará a la conducción. No exceda el límite de velocidad y no conduzca a más de 75 mph (120 km / h).
- 03. Desaceleraciones bruscas (pasar a 10 km/h) al pasar badenes o otros obstáculos. Conduzca suavemente y en forma anticipada a los hechos.
- 04. No se recomienda conducir fuera de la ruta: podría dañar al vehículo, el receptor del enganche, portabicicletas, o las bicicletas.
- 05. Si atraviesas un bache o un agujero en la carretera, detenga su vehículo e inspeccionar las bicicletas y el portador. Si usted nota algo incorrecto, remueve las bicicletas, y no utilice la portabicicletas.
- 06. Asegúrese de que haya una distancia de seguridad entre las bicicletas y el suelo, especialmente al entrarse a un estacionamiento.

### MANUTENCIÓN DEL PORTABICICLETAS

- 01. El usuario es responsable de verificar periódicamente que todo el hardware, las correas, los botones, los centros estén bien apretados por motivos de seguridad.
- 02. No utilice el portador con piezas defectuosas. contacte con el distribuidor para sustituirlo antes de utilizar de nuevo un portador.
- 03. Quite el equipo antes de entrar en un lavadero automático de vehículos.
- 04. Para mantener su producto en las mejores condiciones, se recomienda retirar el producto del vehículo cuando no esté en uso. Tenga en cuenta que este producto no está diseñado para resistir a un clima extremo y sobretodo al aire marítimo demasiado salino.
- 05. Lubrique los tornillos con el fin de evitar la corrosión.

# 주의사항

### 공통 사항

- 01. 제품사용전 동봉된 장착설명서를 숙지하고 추후 사용을 위해 안전한 곳에 보관하시기 바랍니다. 박스 개봉후 동봉된 부품들을 확인합니다. 차량에 장착전 모든 부품들이 설명서에 따라 완벽하게 조립되었는지 확인하십시오.
- 02. 사용자는 본 제품의 조립과 장착에 대한 모든 책임을 지며 제조업자나 판매자는 사용자의 잘못된 장착이나 옹도이외의 사용에 대해서는 아무런 책임을 지지 않습니다
- 03. 본 캐리어와 또는 자전거의 잘못된 장착은 차량과 자전거에 손상을 줄수 있으며 아울러 인사고를 야기할 수 있습니다
- 04. 본 제품을 옹도 이외로 사용하지 마십시오. 제품의 일부분들을 개조하지 마십시오. 비사용시에는 탈착하여 주세요.
- 05. 자전거적재대수를 준수해 주세요. 각각의 자전거의 최대 적재가능 무게는 15kg/33lbs입니다.
- 06. 트레일러나 캠퍼, 캐러밴등에 장착하지 마세요.
- 07. 본 제품은 텐딩이나 리컴벳 적재용으로 사용할 수 없습니다.
- 08. 자전거에 유아용시트, 페니어, 휠커버, 자전거커버나 모터등이 장착된 상태로 운반하지 마십시오.
- 09. 버지비 H2와 H3는 1/ 1/4인치와 2인치 히치바에 함께 사용할 수 있으며 버지비 H4는 2인치 전용입니다
- 10. 1 1/4인치 ( 3.2cm) 와 2인치(5.1cm) 히치리시버에 적합

### 안전 및 적합 사용

- 01. 항상 자전거적재후 자전거와 캐리어사이에는 안전스트랩을 사용하십시오
- 02. 캐리어의 견인바 결합튜브가 차량의 히치리시버에 정확히 조여졌는지 체크하십시오.
- 03. 자전거의 타이어와 캐리어의 스트랩들이 차량의 배기관으로부터 안전한 거리에 위치해 있는지 체크하십시오. 차량의 배기열은 자전거와 캐리어에 손상을 줄수 있습니다.
- 04. 만약 사용차종의 트렁크가 자동 오픈식일 경우, 자전거캐리어 사용시에는 트렁크 기능을 사용할 수 없던가 수동식으로 전환후 사용하셔야 합니다.
- 05. 자전거 적재시에는 자전거에 부착된 분실가능한 부품/용품(공구셋트, 베이비시트, 펌프등)들을 제거후 적재하십시오.
- 06. 항상 차량쪽 기준으로 가장 크고 무거운 자전거부터 적재후 가벼운 자전거들을 적재하십시오.
- 07. 사용자는 사용중 캐리어의 모든 하드웨어나 부품들과 스트랩들이 안전하게 결합되었는지에 대한 책임이 있습니다
- 08. 사용자는 자전거와 차량사이의 스크래치나 간섭을 방지하기 위해 별도의 보호장비들을 사용해야 될 경우들이 발생할 수 있습니다.
- 09. 캐리어에 자전거적재시에는 트렁크를 개폐하지 마십시오.
- 10. 본 잠금장치는 도난 방지 보조용입니다.

### 적재시 안전 수칙

- 01. 자전거캐리어 설치시 차량의 총길이가 증가되며 자전거적재시 역시 폭과 높이가 증가됩니다. 좁은 길, 낮은 도로, 후진시등에 차량의 증가된 부분을 인지하시기 바랍니다. 규정을 초과하는 사용자의 어떠한 적재초과도 기존의 표시규정을 우선할 수 없습니다.
- 02. 캐리어와 자전거의 적재는 차량 운행에 영향을 줄 것입니다. 규정속도를 초과해서는 안되고 도로상황이 좋은곳이라 하더라도 120km/h(75 mph)를 초과할수는 없습니다.
- 03. 방지턱에서는 천천히 운행하십시오. 규정속도를 준수하고 도로상황에 따라 운행속도를 알맞게 조절하십시오.
- 04. 비포장 운행은 비구너장대상이며 경우 자전거와 캐리어, 차량 또는 견인바에 손상을 초래할 수 있습니다.
- 05. 운행중 방지턱이나 옹덩이등에 위해 큰 충격을 받았을때는 정지후 캐리어와 자전거, 차량상태를 검사하시기 바랍니다. 문제점 발견시 자전거를 차량에서 분리하고 캐리어는 안전을 위해 추후 사용을 금합니다.
- 06. 자전거적재후 자전거와 지면 사이의 안전높이를 염두에 두기 바라며 특히 전용도로 진입시 주의하시기 바랍니다

### 유지 관리

- 01. 사용중에 제품의 벗겨짐, 부식, 갈라짐등을 검사하십시오.
- 02. 손상된 부분이 있는 캐리어는 사용을 하지 마십시오. 재사용시에는 판매처등에 의뢰해 손상부위를 교체후 사용하시기 바랍니다.
- 03. 자동세차시에는 캐리어를 탈착하시기 바랍니다.
- 04. 캐리어를 효과적으로 유지하기 위해서 비사용시 캐리어를 차량으로부터 탈거합니다. 본 제품은 해안가의 공기나 극심한 날씨등에 견딜수 있도록 디자인되어 있지는 않다는 것을 안내드립니다.
- 05. 녹방지를 위해 볼트등에 윤활제를 발라주세요.