

2

Bolero XL

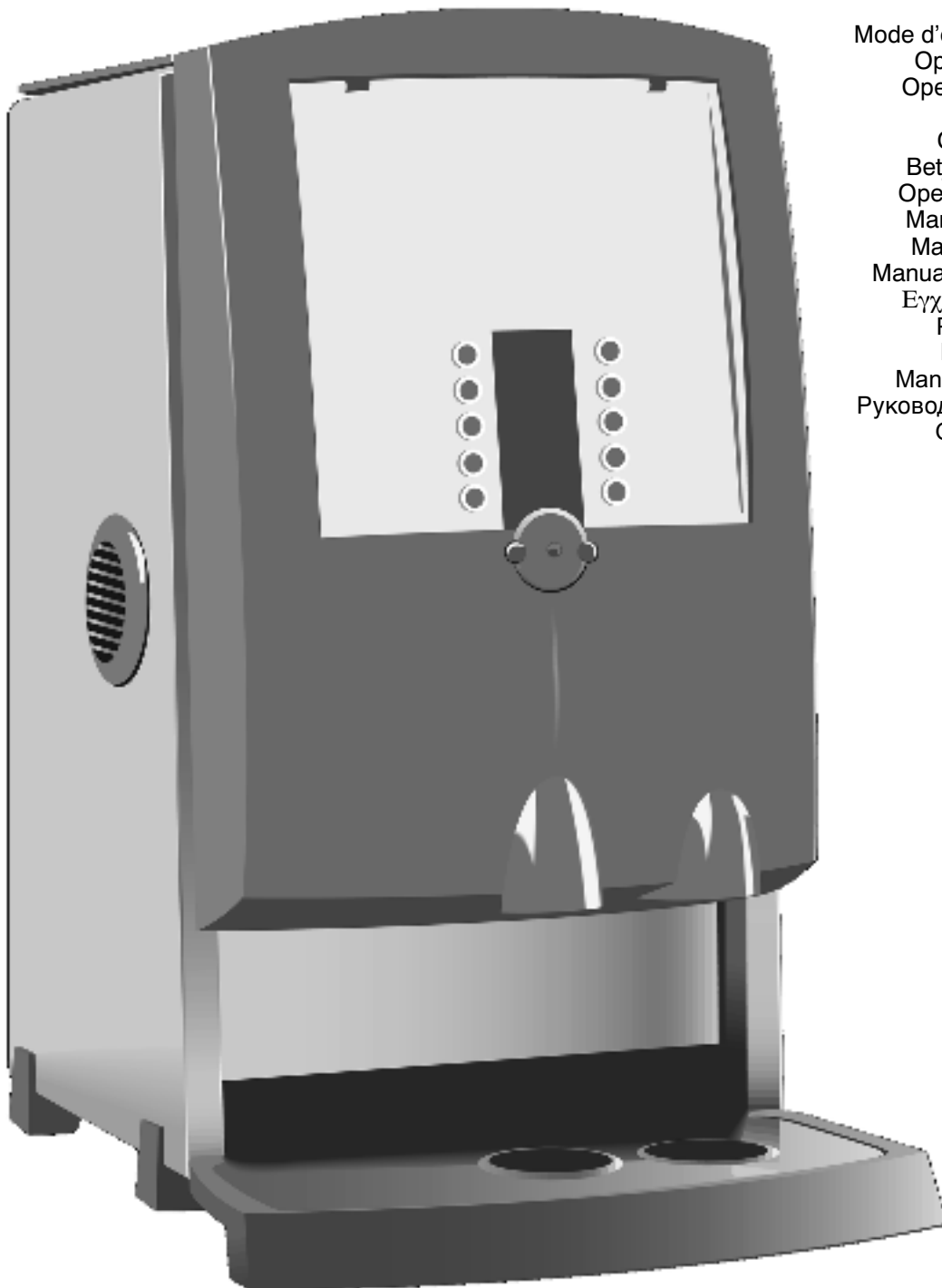

Operator manual
Mode d'emploi Opérateur
Operator Handbuch
Operator handleiding
Driftmanual
Operatørhåndbok
Betjeningsvejledning
Operaattorin käsikirja
Manual del operador
Manual do operador
Manuale per l'operatore
Εγχειρίδιο χειρισμού
Provozní příručka
Instrukcja obsługi
Manualul operatorului
Руководство оператора
Operatör kilavuzu
操作手冊
操作マニュアル
동자 설명서

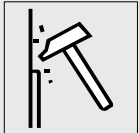

English
Français
Deutsch
Nederlands
Svenska

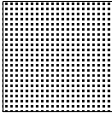

Norsk
Dansk
Suomi
Español
Português

Information
Information
Information
Informatie
Informação



Informasjon
Information
Informaatio
Información
Informação

Table of contents
Table des matières
Inhaltsangabe
Inhoudsopgave
Innehållsförteckning



Innholdsfortegnelse
Indholdsfortegnelse
Sisällysluettelo
Contenido
Índice

Installation
Installation
Installation
Installeren
Instalação



Installasjon
Installation
Asennus
Instalar
Instalação

Descaling
Détartrage
Entkalkung
Ontkalken
Avkalkning

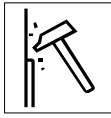

Rensing
Afkalkning
Kalkinpoisto
Descalcificación
Descalcificação

Programming
Programmation
Programmieren
Programmeren
Programmering



Programmering
Programmering
Ohjelmointi
Programar
Programação

Safety book
Sommaire des sécurités
Sicherheitsvorschriften
Veiligheidsboek
Säkerhetsföreskrifter



Sikkerhetsbok
Sikkerhedsbog
Turvallisuusohjeet
Libro de seguridad
Instruções de segurança

User manual
Mode d'emploi Utilisateur
Gebraucher Handbuch
Gebruiksaanwijzing
Användarmanual

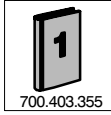

Brugerhåndbok
Brugsanvisning
Käyttäjän käsikirja
Manual del usuario
Manual do operador

List of ingredients
Liste des ingrédients
Produktliste
Ingrediëntenblad
Ingredienslista

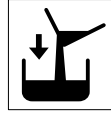

Ingrediensliste
Ingrediens liste
Ainesosaluettelo
Lista de ingredientes
Lista de ingredientes

Wait
Patienter
Warten
Wachten
Vänta



Vent
Vent
Odota
Esperar
Aguardar

Safety gloves
Gants de sécurité
Schutzhandschuh
Veiligheidshandschoenen
Skydds handskar



Hansker
Sikkerheds handsker
Suojahanskat
Zapatos de seguridad
Luvas de protecção

Safety goggles
Lunettes de sécurité
Schutzbrille
Veiligheidsbril
Skydds glasögon

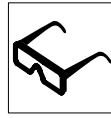

Vernebriller
Sikkerhedsbriller
Suojalasit
Gafas de seguridad
Óculos de protecção

Hot liquid
Liquide chaud
Heiße Flüssigkeit
Hete vloeistof
Varma drycker



Varm væske
Varm flydende
Kuuma nestettä
Líquido caliente
Líquido quente

Counter
Compteur
Zähler
Teller
Räknare



Telleverk
Tæller
Laskin
Contador
Contador

Accessories
Accessoires
Zubehör
Toebehoren
Tillbehör

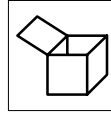

Tilbehør
Valgbar
Lisälaitteet
Accesorios
Acessórios

Optional
Option
Produktliste
Optioneel
Tillval

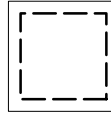

Valgfri
Tilbehør
Valinnainen
Opcional
Opcional

it : Per la Sua lingua consultare la fine di questo documento.
el : Στην αναδιπλωμένη σελίδα, στο τέλος του εντύπου, μπορείτε να κοιτάξετε για τους όρους στη γλώσσα σας.
cz : Volba jazyka je popsána na konci následující stránky tohoto návodu.
pl : Szukaj swojego języka na ostatnich stronach dokumentu.
ro : Citiți pentru limba dvs pagina atașată la spatele acestui document.
ru : Вкладыш на Вашем языке в конце этого документа.
tr : Diliniz için arkadaki katlı sayfaya bakınız.
ch : 查看背頁的所屬語文
jp : 各言語についてはこの説明書の最後のページをご参照ください。
kor : 자료의 뒷면 접은 페이지에서 해당언어를 참조 하시오



Installation
Installation
Installation
Installieren
Installation

Installasjon
Installation
Asennus
Instalar
Instalação

Installazione
Εγκατάσταση
Instalace
Instalacja
Operare

Установка
Yerleştirme
安裝
設置
설치

1



Programming
Programmation
Programmieren
Programmeren
Programmering

Programmering
Programmering
Ohjelmointi
Programar
Programação

Programmazione
Προγραμματισμός
λειτουργίας
Programování
Programowanie
Programare

Программирование
Programlama
程式
プログラミング
프로그래밍

7

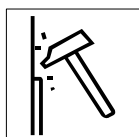

Descaling
Détartrage
Entkalkung
Ontkalken
Avkalkning

Rensing
Afkalkning
Kalkinpoisto
Descalcificación
Descalcificação

Decalcificazione
Αφαλάτωση
Odvápnění
Odkamienianie
Decalcarizare

уистка от накипи
Kireçten arındırma
除垢
デスケール
스케일 청소

19

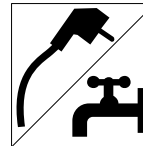

Installation
Installation
Installation
Installieren
Installation

Installasjon
Installation
Asennus
Instalar
Instalação

Installazione
Εγκατάσταση
Instalace
Instalacja
Operare

Установка
Yerleştirme
内容目錄
目次
목 차

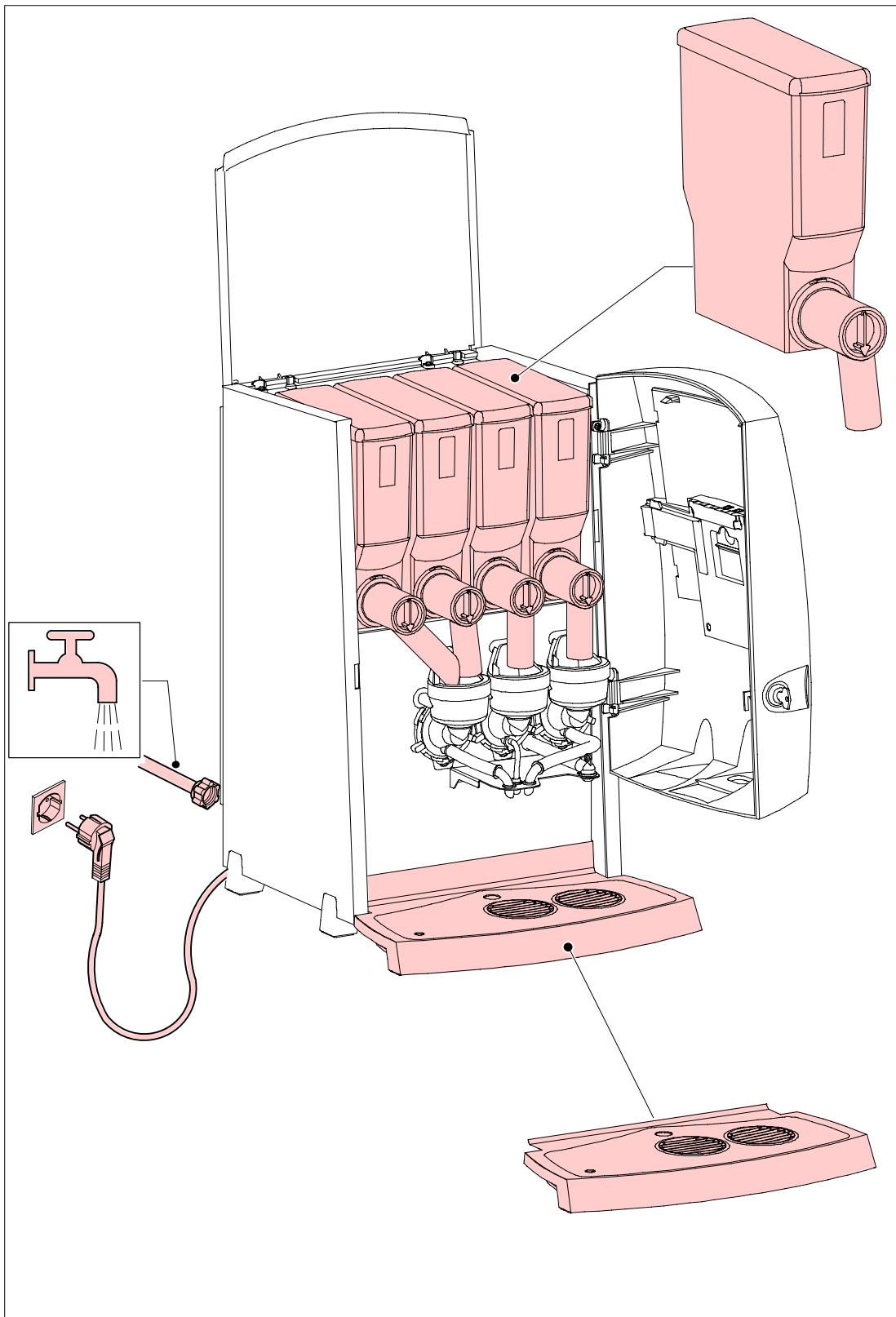

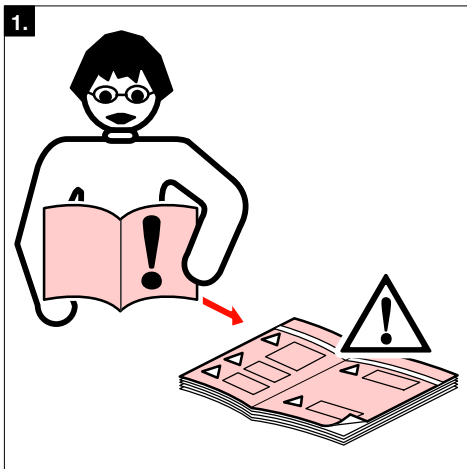

700.403.347

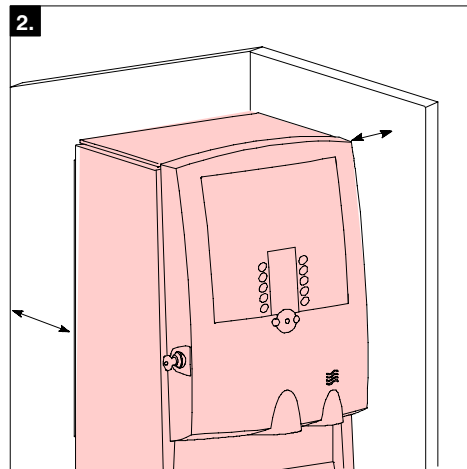

700.403.347

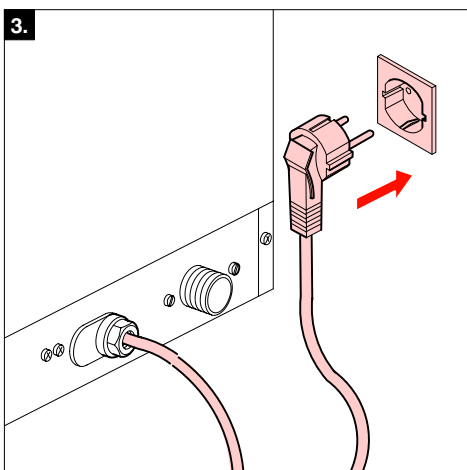

700.403.347

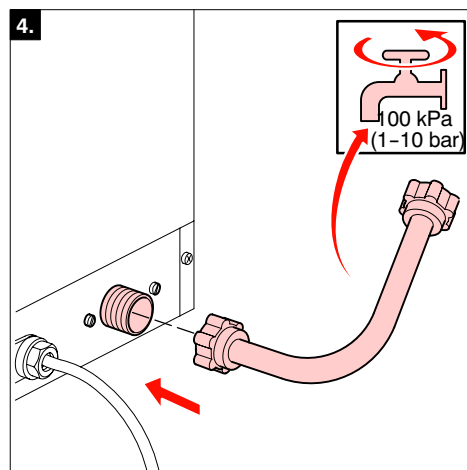

700.403.347

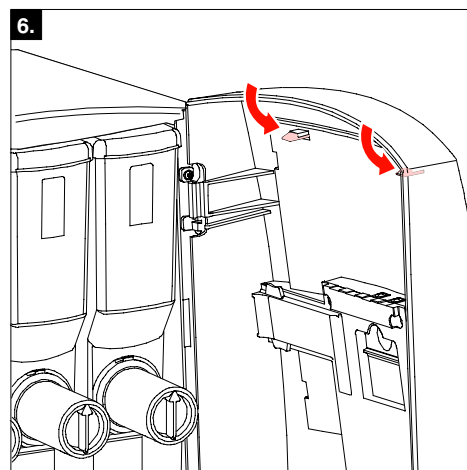
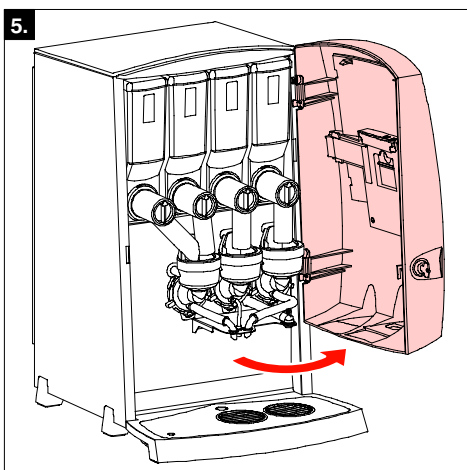

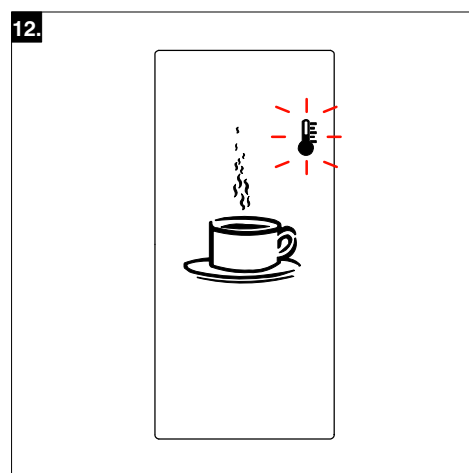
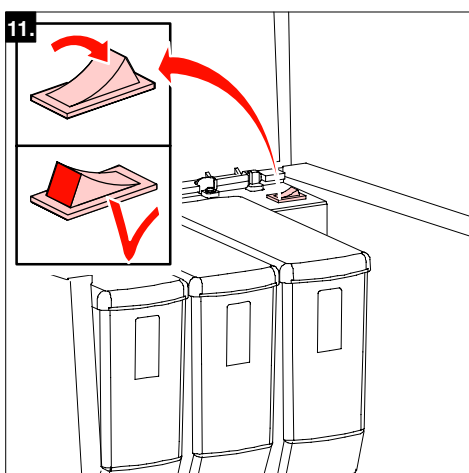
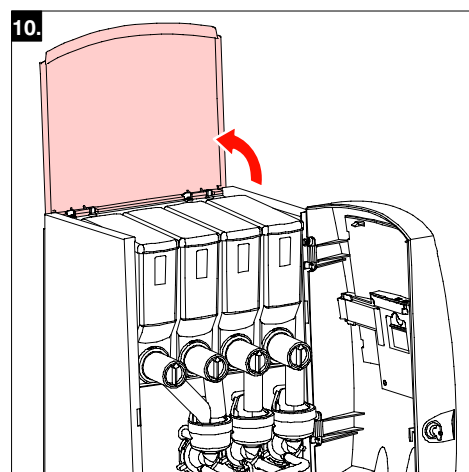
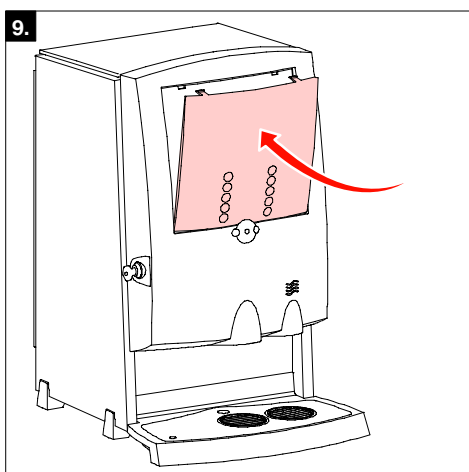
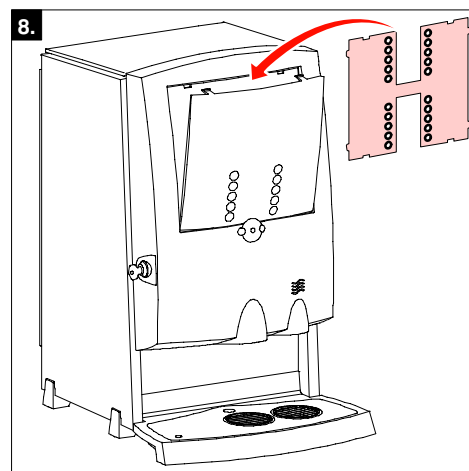
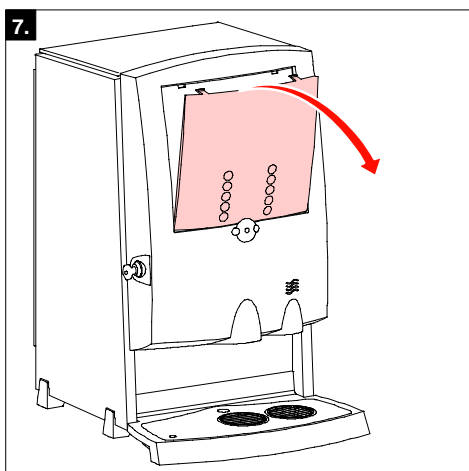
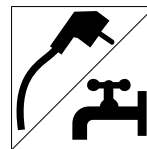

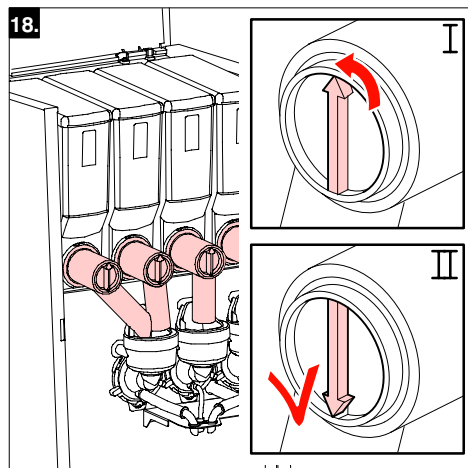
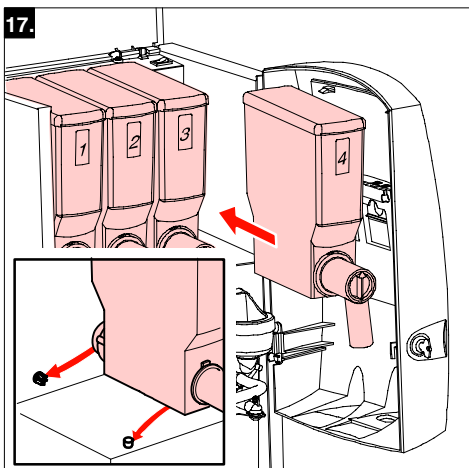
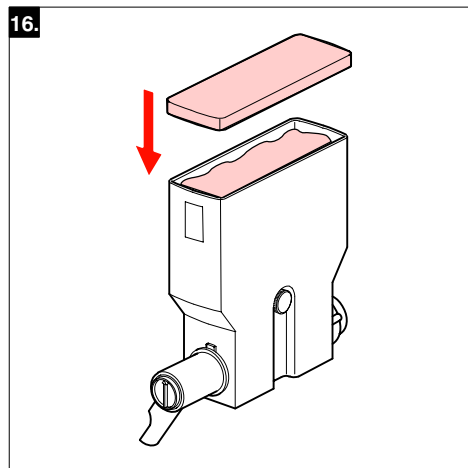
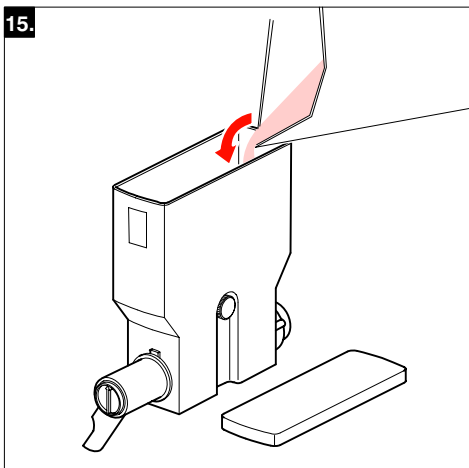
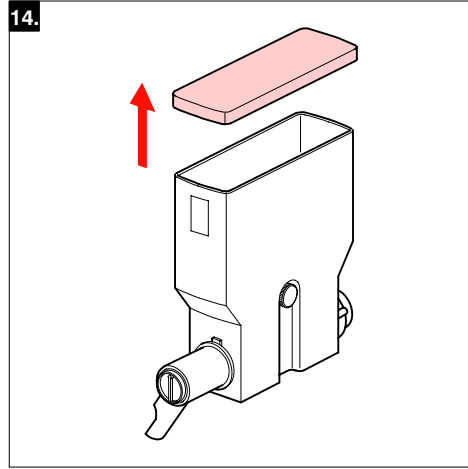
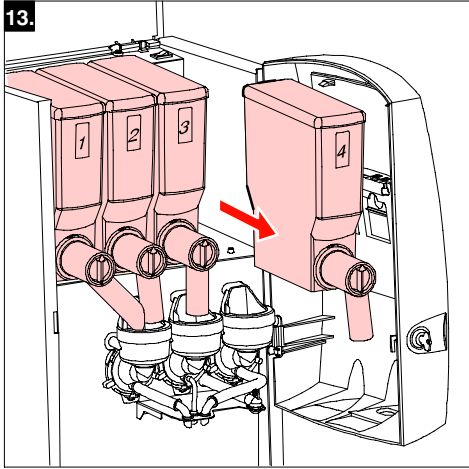

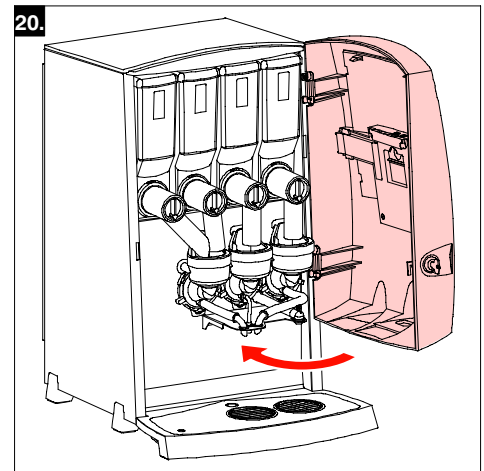
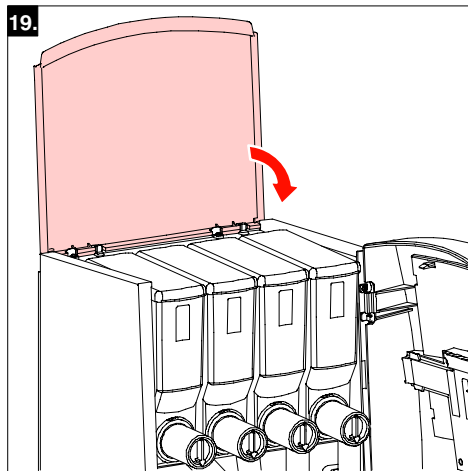

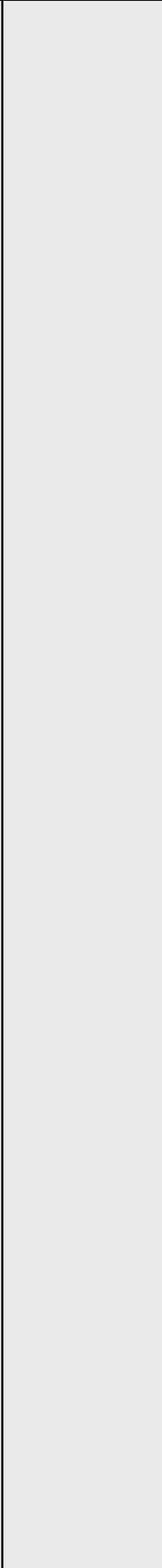

Programming
Programmation
Programieren
Programmeren
Programmering

Programmering
Programmering
Ohjelmointi
Programar
Programação

Programmazione
Προγραμματισμός
λειτουργίας
Programování
Programowanie
Programare

Программирование
Programlama
程式
プログラミング
프로그램



P

	☒	☐	▲	■	▣
English	Off	Minimum value	Standard value	Maximum value	Next step / confirm
Français	Eteint	Valeur minimum	Valeur standard	Valeur maximum	Etape suivante / confirmer
Deutsch	Aus	Minimum Wert	Standard Wert	Maximum Wert	Nächster Schritt / sichern
Nederlands	Uit	Minimum waarde	Standaard waarde	maximum waarde	Volgende stap / bevestigen
Svenska	Av	Minimum värde	Standard värde	Maximalt värde	Nästa steg / Bekräfta
Norsk	Av	Minimum verdi	Standard verdi	Maksimum verdi	Neste steg / Bekreft
Dansk	Slukket	Minimum værdi	Standard værdi	Maksimum værdi	Næste trin / Bekræft
Suomi	Pois päältä	Minimi arvo	Oletusarvo	Maksimi arvo	Seuraava / Vahvista
Español	Apagado	Valor mínimo	Valor estándar	Valor máximo	Próximo nivel / confirmar
Português	Desligado	Valor mínimo	Valor standard	Valor máximo	Próximo passo / confirme
Italiano	Spento	Valore minimo	Valore standart	Valore massimo	Prossimo / passo
Ελληνικά	Εκτός λειτουργίας	Ελάχιστη τιμή	Θυσιολογική τιμή	Μύγιστη τιμή	Επόμενο βήμα / επιβεβαίωση
Česky	Vyprnutí	Minimální hodnota	Standardní hodnota	Maximální hodnota	Další krok / potvrdit
Polski	Wyłączony	Minimalna wartość	Standardowa wartość	Maksymalna wartość	Następny krok / potwierdzenie
Română	Oprit	Valoare minimă	Valoare standard	Valoare maximă	Pasul următor / confirma
Русский	Выключено	Минимальный объем	Стандартный объем	Максимальный объем	Следующий шаг / Подтвердить
Türkçe	Kapalı	Minimum değer	Standart değer	Maksimum değer	Sonraki adım / Onayla
中文	關閉	最小價值	標準價值	最大價值	下一步/確認
日本語	オフ	最小値	標準値	最大値	次のステップ
한국말	끄 짐	최소치	표준치	최대치	다음단계/확인

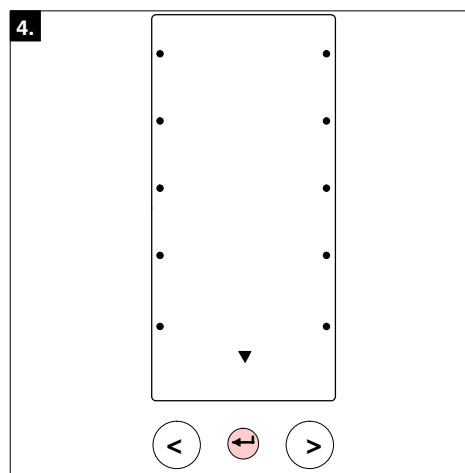
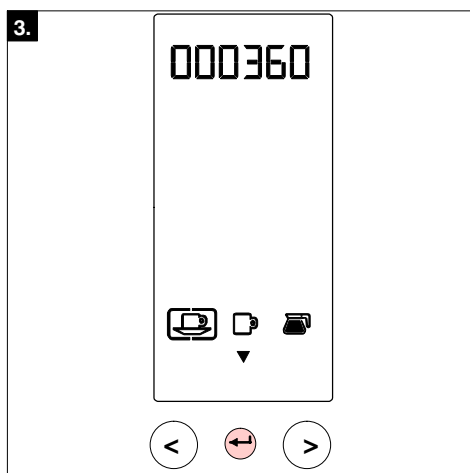
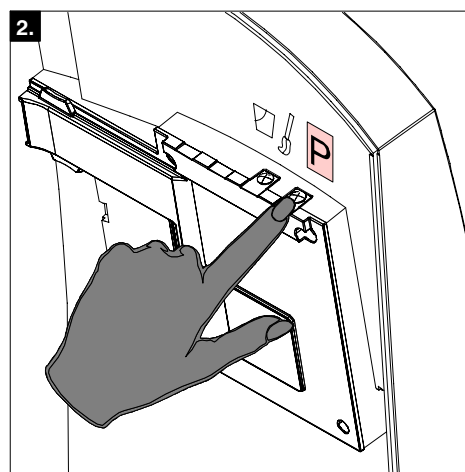
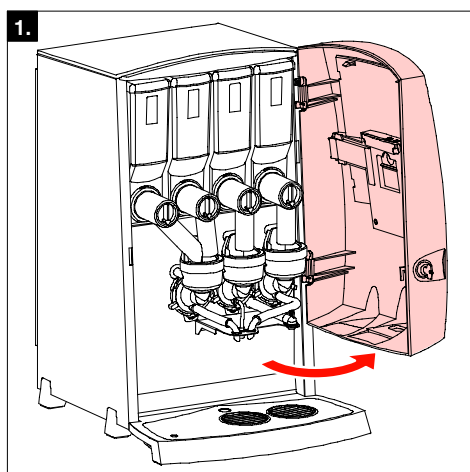

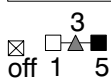
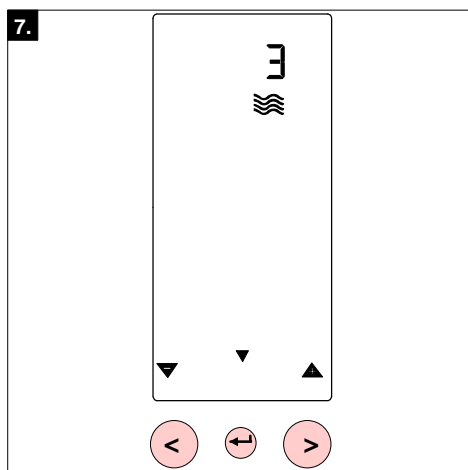
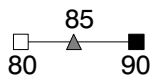
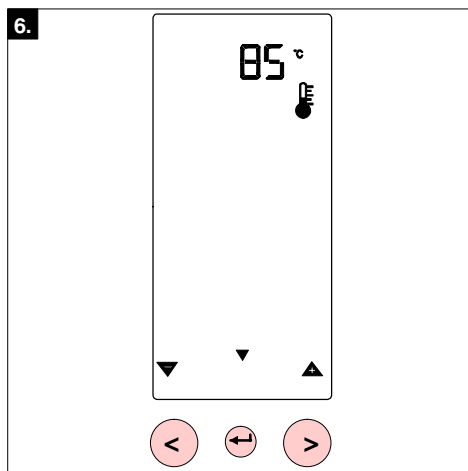
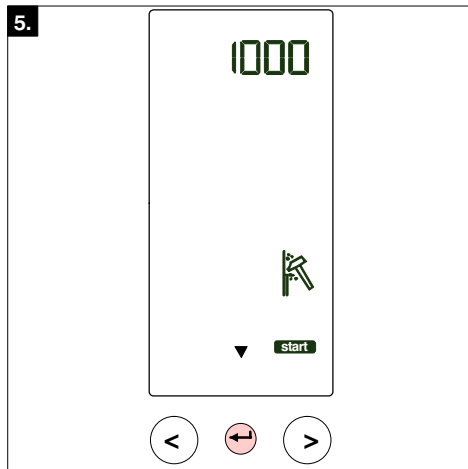

Scale Icon	Setting	Temperature Range	Volume
☒	OFF		
☐	1	18 - 30 °DH = 32 - 55 °TH	250 L.
▲	2	12 - 18 °DH = 22 - 32 °TH	500 L.
■	3	08 - 12 °DH = 15 - 22 °TH	1000 L.
	4	04 - 08 °DH = 07 - 15 °TH	1500 L.
	5	00 - 04 °DH = 00 - 07 °TH	2000 L.
	4,0 °DH = 0,714 mmol/l		
	10,0 °TH = 1,000 mmol/l		

Boiler temperature
 Température chaudière
 Boiler Temperatur
 Boiler temperatuur
 Temperatur kokare
 Elementtemperatur
 Vand temperatur
 Säiliön lämpötila
 Temperatura de la resistencia
 Temperatura da caldeira
 Temperatura boiler
 Θερμοκρασία λέβητα
 Teplota boileru
 Temperatura bojlera
 Temperatură boiler
 Температура в бойлере
 Boyler derecesi
 熱水器溫度
 ボイラー温度
 보일러 온도

Descaling signal
 Signalisation d' entartrage
 Entkalkungsanzeige
 Ontkalkingsignalering
 Avkalkningssignal
 Rensesignal
 Afkalknings signal
 Kalkinpoistomerkki
 Señalización de descalcificación
 Sinal de descalcificação
 Identificazione della decalcificazione
 Ένδειξη αφάλατωσης
 Signal odvápnění
 Sygnał akustyczny odkamieniania
 Semnal decalcarizare
 Сигнал для Ристки от накипи
 Kireçten arındırma sinyali
 除垢訊號
 デスケール表示
 스케일 청소 표시

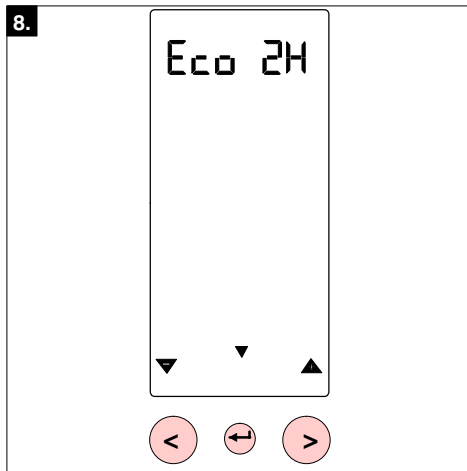

off 0.15 2H 16H

Energy-saving mode
 Mode économique
 Energiesparstufe
 Energie spaarstand
 Energisparläge
 Energisparingsmodus
 Energi spare funktion
 Sähköä säästävä malli
 Posición de economía
 Economizador de energia
 Risparmio energia
 Ένδειξη εξοικονόμησης ενέργειας
 Ochrona energie
 Tryb pracy "eco" oszczędzający energię
 Mod economic
 Экономичный режим
 Enerji tassarufu modu
 能源節省模式
 省エネモード
 에너지 절약형 모드

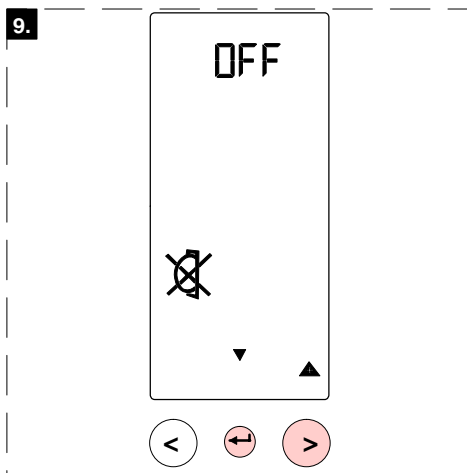

Coin mechanism
 Monnayeur
 Münzprüfer
 Muntmechanisme
 Myntmekanism
 Myntmekanisme
 Møntsystem
 Kolikkomekanismi
 Mecanismo de monedas
 Moedeiro
 Controllo monete
 Μηχανισμός κερμάτων
 Mincovní mechanismus
 Mechanizm monetowy
 Mecanism cu fise
 Монетоприемник
 Bozuk para mekanizması
 硬幣裝置

コインメック
 코인 메커니즘

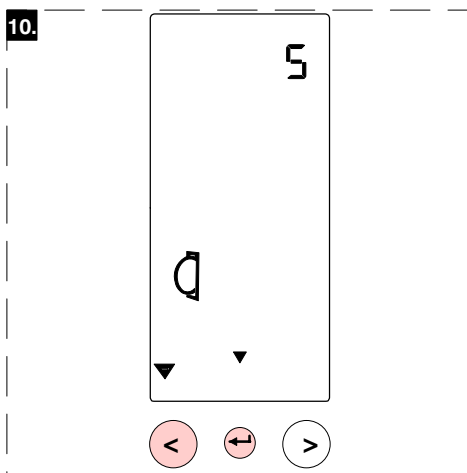

Coins rejection / acceptance (0.05)
 Refus / acceptation de monnaie (0.05)
 Münzen abgelehnt/ akzeptiert (0.05)
 Munt weigering / acceptatie (0.05)
 Myntretur / accepteras (0.05)
 Mynt avvisning / aksept (0.05)
 Mønt retur / accepteret (0.05)
 Kolikon hylkäys / hyväksyminen (0.05)
 Negación / aceptación de monedas (0.05)
 Rejeição de moeda / aceitação (0.05)
 Accettazione / rifiuto moneta (0.05)
 Απόρριψη / Αποδοχή κερμάτων (0.05)
 Možnost připojení / mincovníku (0.05)
 Likwidacja mechanizmu monetowego monet /
 akceptacja (0.05)
 Acceptare / respingere fisă (0.05)
 Монета непригодна / пригодна (0.05)
 Bozuk para geri çevirme / kabul (0.05)
 硬幣退回/接受 (0.05)
 コイン却下・受け入れ (0.05)
 코인 제거/접수 (0.05)

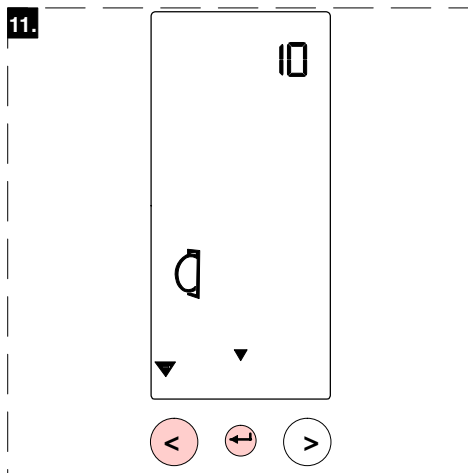

Coins rejection / acceptance (0.10)
 Refus / acceptation de monnaie (0.10)
 Münzen abgelehnt/ akzeptiert (0.10)
 Munt weigering / acceptatie (0.10)
 Myntretur / accepteras (0.10)
 Mynt avvisning / aksept (0.10)
 Mønt retur / accepteret (0.10)
 Kolikon hylkäys / hyväksyminen (0.10)
 Negación / aceptación de monedas (0.10)
 Rejeição de moeda / aceitação (0.10)
 Accettazione / rifiuto moneta (0.10)
 Απόρριψη / Αποδοχή κερμάτων (0.10)
 Možnost připojení / mincovníku (0.10)
 Likwidacja mechanizmu monetowego monet /
 akceptacja (0.10)
 Acceptare / respingere fisă (0.10)
 Монета непригодна / пригодна (0.10)
 Bozuk para geri çevirme / kabul (0.10)
 硬幣退回/接受 (0.10)
 コイン却下・受け入れ (0.10)
 코인 제거/접수 (0.10)

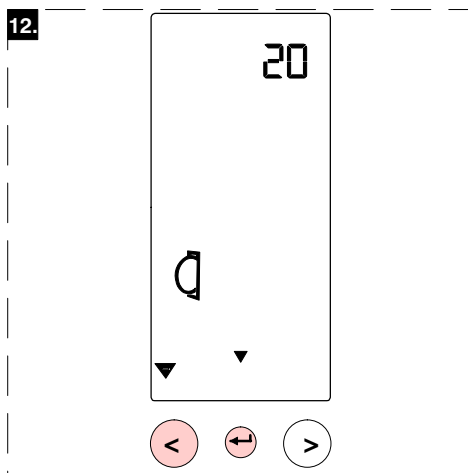

Coins rejection / acceptance (0.20)
 Refus / acceptation de monnaie (0.20)
 Münzen abgelehnt/ akzeptiert (0.20)
 Munt weigering / acceptatie (0.20)
 Myntretur / accepteras (0.20)
 Mynt avvisning / aksept (0.20)
 Mønt retur / accepteret (0.20)
 Kolikon hylkäys / hyväksyminen (0.20)
 Negación / aceptación de monedas (0.20)
 Rejeição de moeda / aceitação (0.20)
 Accettazione / rifiuto moneta (0.20)
 Απόρριψη / Αποδοχή κερμάτων (0.20)
 Možnost připojení / mincovníku (0.20)
 Likwidacja mechanizmu monetowego monet /
 akceptacja (0.20)
 Acceptare / respingere fisă (0.20)
 Монета непригодна / пригодна (0.20)
 Bozuk para geri çevirme / kabul (0.20)
 硬幣退回/接受 (0.20)
 コイン却下・受け入れ (0.20)
 코인 제거/접수 (0.20)

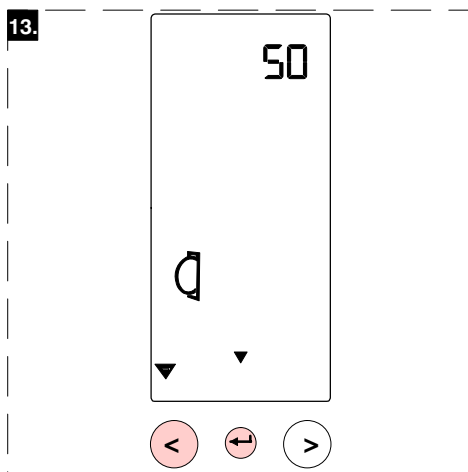

Coins rejection / acceptance (0.50)
 Refus / acceptation de monnaie (0.50)
 Münzen abgelehnt/ akzeptiert (0.50)
 Munt weigering / acceptatie (0.50)
 Myntretur / accepteras (0.50)
 Mynt avvisning / aksept (0.50)
 Mønt retur / accepteret (0.50)
 Kolikon hylkäys / hyväksyminen (0.50)
 Negación / aceptación de monedas (0.50)
 Rejeição de moeda / aceitação (0.50)
 Accettazione / rifiuto moneta (0.50)
 Απόρριψη / Αποδοχή κερμάτων (0.50)
 Možnost připojení / mincovníku (0.50)
 Likwidacja mechanizmu monetowego monet /
 akceptacja (0.50)
 Acceptare / respingere fisă (0.50)
 Монета непригодна / пригодна (0.50)
 Bozuk para geri çevirme / kabul (0.50)
 硬幣退回/接受 (0.50)
 コイン却下・受け入れ (0.50)
 코인 제거/접수 (0.50)

P

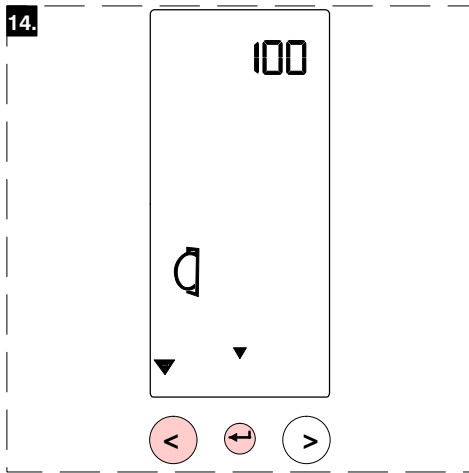

Coins rejection / acceptance (1.00)
 Refus / acceptation de monnaie (1.00)
 Münzen abgelehnt/ akzeptiert (1.00)
 Munt weigering / acceptatie (1.00)
 Myntretur / accepteras (1.00)
 Mynt avvisning / aksept (1.00)
 Mønt retur / accepteret (1.00)
 Kolikon hylkäys / hyväksyminen (1.00)
 Negación / aceptación de monedas (1.00)
 Rejeição de moeda / aceitação (1.00)
 Accettazione / rifiuto moneta (1.00)
 Απόρριψη / Αποδοχή κερμάτων (1.00)
 Možnost připojení / mincovníku (1.00)
 Likwidacja mechanizmu monetowego monet /
 akceptacja (1.00)
 Acceptare / respingere fisă (1.00)
 Монета непригодна / пригодна (1.00)
 Bozuk para geri çevirme / kabul (1.00)
 硬幣退回/接受 (1.00)
 コイン却下・受け入れ (1.00)
 코인 제거/접수 (1.00)

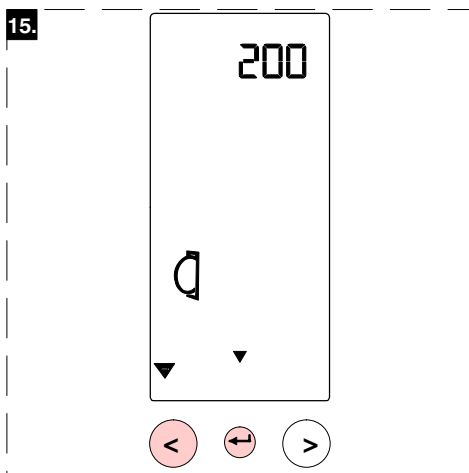

Coins rejection / acceptance (2.00)
 Refus / acceptation de monnaie (2.00)
 Münzen abgelehnt/ akzeptiert (2.00)
 Munt weigering / acceptatie (2.00)
 Myntretur / accepteras (2.00)
 Mynt avvisning / aksept (2.00)
 Mønt retur / accepteret (2.00)
 Kolikon hylkäys / hyväksyminen (2.00)
 Negación / aceptación de monedas (2.00)
 Rejeição de moeda / aceitação (2.00)
 Accettazione / rifiuto moneta (2.00)
 Απόρριψη / Αποδοχή κερμάτων (2.00)
 Možnost připojení / mincovníku (2.00)
 Likwidacja mechanizmu monetowego monet /
 akceptacja (2.00)
 Acceptare / respingere fisă (2.00)
 Монета непригодна / пригодна (2.00)
 Bozuk para geri çevirme / kabul (2.00)
 硬幣退回/接受 (2.00)
 コイン却下・受け入れ (2.00)
 코인 제거/접수 (2.00)



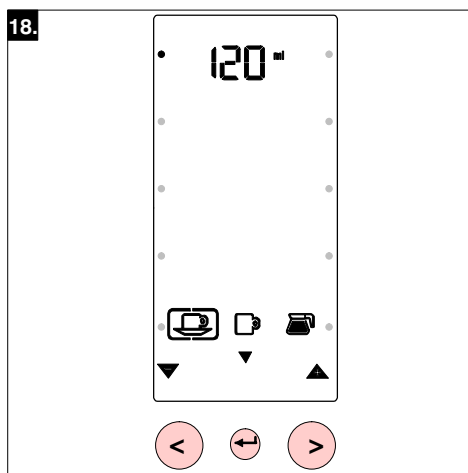
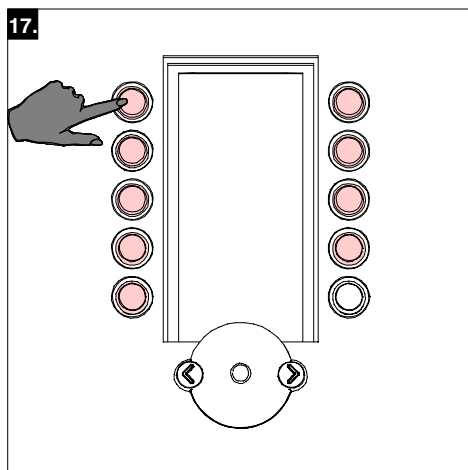
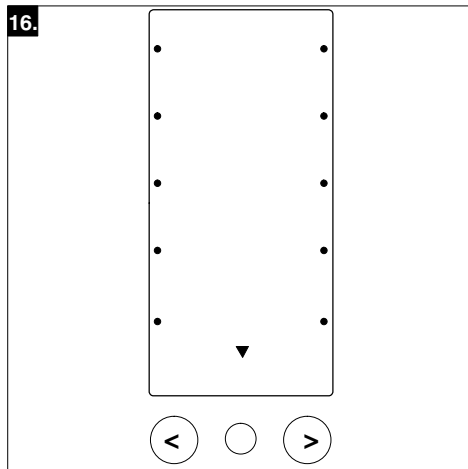

☒ ☐ ————— ■
off 20 720

Programming (drink dependent)
 Programmation (selon boisson)
 Programmieren (Getränke abhängig)
 Programmeren (drank afhankelijk)
 Programmering (färdig dryck)
 Programmering (drikkeavhengig)
 Programmering (afhængig af drik)
 Ohjelmointi (juomakohtainen)
 Programar (dependiendo a la bebida)
 Programação (bebida dependente)
 Programmazione (dipendendo bevando)
 Προγραμματισμός λειτουργίας (αναλόγως ποτού)
 Programování (závisí na nápoji)
 Programowanie (w zależności od rodzaju napoju)
 Programar (dependentă de băutură)
 Программирование (выбранного напитка)
 Programlama (İçeceğe bağlı)
 程式 (按飲品)
 プログラミング (種類別に設定)
 프로그램 (음료의 종류에 따라 다름)

Amount per cup (drink dependent)
 Quantité par tasse (selon boisson)
 Füllmenge Tasse (Getränke abhängig)
 Doseergrootte kop (drank afhankelijk)
 Kvantitet/kopp (färdig dryck)
 Mengde pr. kopp (drikkeavhengig)
 Mængde pr. kop (afhængig af drik)
 Määrä / kuppi (juomakohtainen)
 Dos. grandeza de taza (dependiendo a la bebida)
 Quantidade por chávena (bebida dependente)
 Dosaggio per tazza (dipendendo bevando)
 Ποσότητα ανά φλιτζάνι (αναλόγως ποτού)
 Množství na šálek (závisí na nápoji)
 Ilość na filiżankę (w zależności od rodzaju napoju)
 Cantitate per ceașcă (dependentă de băutură)
 Доза выбранного напитка на Рашку
 Bir fincan için miktarı (İçeceğe bağlı)
 每小杯份量 (按飲品)
 小カップ一杯当りの量 (種類別に設定)
 컵당 량 (음료의 종류에 따라 다름)

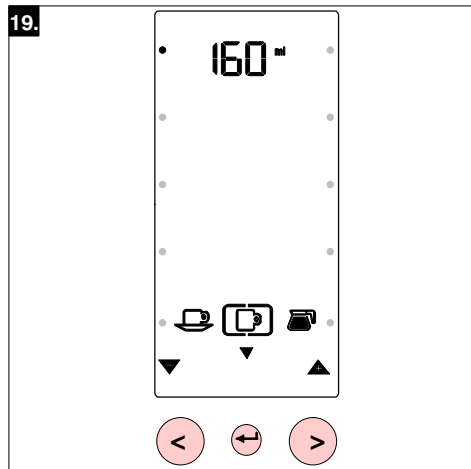

☒ ☐ off 20 720

Amount per mug (drink dependent)
 Quantité par grande tasse (selon boisson)
 Füllmenge Becher (Getränk abhängig)
 Doseergroote beker (drank afhankelijk)
 Kvantitet/mugg (färdig dryck)
 Mengde pr. krus (drikkeavhengig)
 Mængde pr. krus (afhængig af drik)
 Määrä / muki (juomakohtainen)
 Dos. grandeza de tazón (dependiendo a la bebida)
 Quantidade por caneca (bebida dependente)
 Dosaggio tazza grande (dipendendo bevando)
 Ποσότητα ανά κούπα (αναλόγως ποτού)
 Množství na džbánek (závisí na nápoji)
 Ilość na kubek (w zależności od rodzaju napoju)
 Cantitate per cană (dependentă de băutură)
 Доза выбранного напитка на кружку
 Bir maşrapa için miktarı (İçeceği bağlı)
 每大杯份量(按飲品)

大カップ一杯当りの量 (種類別に設定)
 머그컵당 량(음료의 종류에 따라 다름)

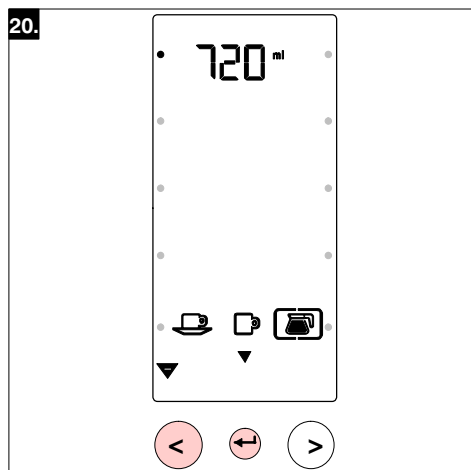

☒ ☐ off 20 720

Amount per decanter (drink dependent)
 Quantité par pichet (selon boisson)
 Füllmenge Kanne (Getränk abhängig)
 Doseergroote kan (drank afhankelijk)
 Kvantitet/kanna (färdig dryck)
 Mengde pr. kanne (drikkeavhengig)
 Mængde pr. kande (afhængig af drik)
 Määrä / kannu (juomakohtainen)
 Dos. grandeza de jarra (dependiendo a la bebida)
 Quantidade por jarro (bebida dependente)
 Dosaggio per Bricco (dipendendo bevando)
 Ποσότητα ανά κανάτα (αναλόγως ποτού)
 Množství na konvici (závisí na nápoji)
 Ilość na dzbanek (w zależności od rodzaju napoju)
 Cantitate per bol (dependentă de băutură)
 Доза выбранного напитка на графин
 Bir pot için miktarı (İçeceği bağlı)
 每壺份量(按飲品)

デカンター一杯当りの量 (種類別に設定)
 디켄터당 량(음료의 종류에 따라 다름)

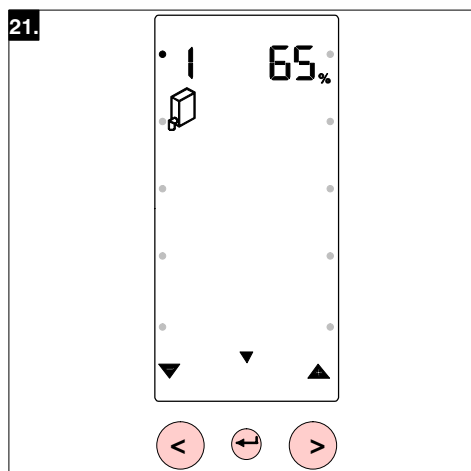

☒ ☐ off 5 100

Basic strength (drink dependent)
 Réglage goût de base (selon boisson)
 Basis Stärke (Getränk abhängig)
 Basis sterkte (drank afhankelijk)
 Normal styrka (färdig dryck)
 Grunnstyrke (drikkeavhengig)
 Standard styrke (afhængig af drik)
 Normaali vahvuus (juomakohtainen)
 Fuerza básica (dependiendo a la bebida)
 Dureza básica (bebida dependente)
 Gusto standart (dipendendo bevando)
 Βασική ισχύς (αναλόγως ποτού)
 Základní množství (závisí na nápoji)
 Podstawowa moc (w zależności od rodzaju napoju)
 Concentrație de bază (dependentă de băutură)
 Базовая насыщенность выбранного напитка
 Normal kuvvette (İçeceği bağlı)
 基本濃度(按飲品)

標準濃度 (種類別に設定)
 기본농도(음료의 종류에 따라 다름)

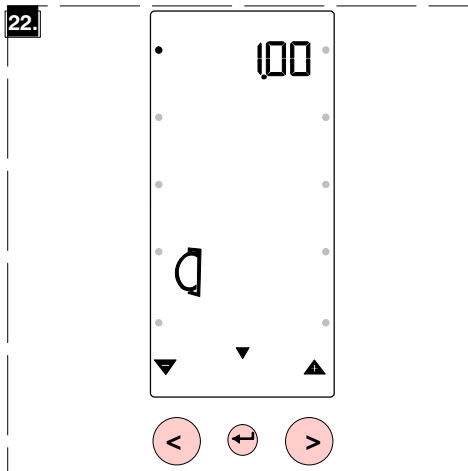

- Price-fixing (drink dependent)
- Indice prix (selon boisson)
- Preis (Getränke abhängig)
- Prijsstelling (drank afhankelijk)
- Bestäm pris (färdig dryck)
- Satt pris (drikkeavhengig)
- Pris indstilling (afhængig af drik)
- Hinnan sääätö (juomakohtainen)
- Regulación de precios (dependiendo a la bebida)
- Atribuir preço (bebida dependente)
- Prezzo (dipendendo bevando)
- Ρυθμιστής τιμής (αναλόγως ποτού)
- Programování ceny (závisí na nápoji)
- Ustawianie ceny (w zależności od rodzaju napoju)
- Cotă stabilită in pret (dependent de băutura)
- Цена выбранного напитка
- Ücret sabitleme (İçeceği bağı)
- 定價 (按飲品)
- 価格設定 (種類別に設定)
- 고정가격(음료의 종류에 따라 다름)

P

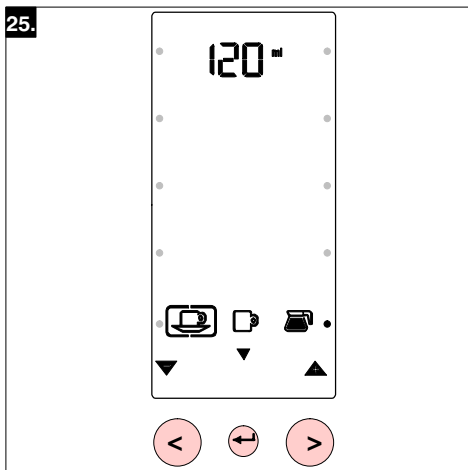
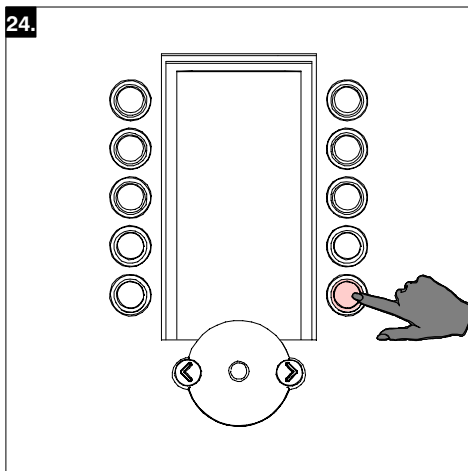
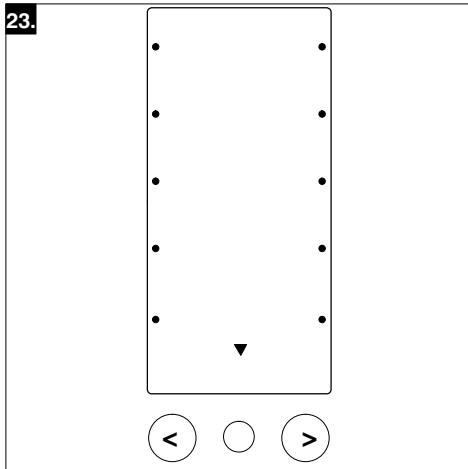

☒ □ ————— ■
off 20 720

Programming (hot water)
 Programmation (d'eau chaude)
 Programmieren (Heißwasser)
 Programmeren (hot water)
 Programmering (hetvatten)
 Programmering (varmt vann)
 Programmering (varmt vand)
 Ohjelmointi (kuuma vesi)
 Programar (agua caliente)
 Programação (água quente)
 Programmazione (acqua calda)
 Προγραμματισμός λειτουργίας (καυτού νερού)
 Programování (horké vody)
 Programowanie (wody gorącej)
 Programar (fierbinte)
 Программирование (горячей воды)
 Programlama (sıcak su)
 程式 (熱水)
 プログラミング (熱湯)
 프로그램 (더운물)

Amount of hot water per cup
 Quantité d'eau chaude par tasse
 Füllmenge Tasse Heißwasser
 Doseergrootte kop heet water
 Kvantitet hetvatten/kopp
 Mengde varmt vann pr. kopp
 Mængde af varmt vand pr. kop
 Kuuman veden määrä / kuppi
 Dosificación grandeza de taza de agua caliente
 Quantidade de água quente por chávena
 Quantità acqua calda per tazza
 Ποσότητα καυτού νερού ανά φλιτζάνι
 Množství horké vody na šálek
 Ilość wody gorącej na filiżankę
 Cantitatea apă fierbinte per ceașcă
 Количество горячей воды на Рашку
 Bir fincan için sıcak su miktarı
 每小杯熱水份量
 小カップ一杯当りの熱湯の量
 컵당 더운물의 량

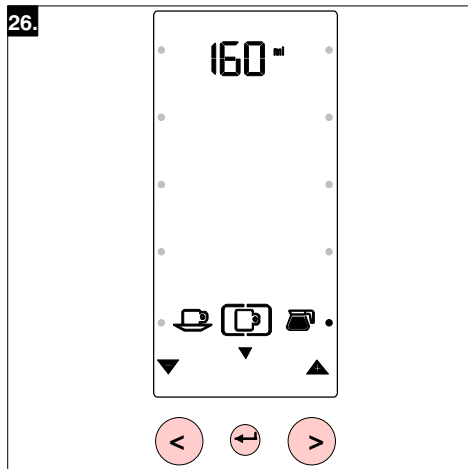

☒ ☐ ————— ■
off 20 720

Amount of hot water per mug
Quantité d'eau chaude par grande tasse
Füllmenge Becher Heißwasser
Doseergrootte beker heet water
Kvantitet hetvatten/mugg
Mengde varmt vann pr. krus
Mængde af varmt vand pr. krus
Kuuman veden määrä / muki
Dosificación grandeza de tazón de agua caliente
Quantidade de água quente por caneca
Quantità acqua calda per tazza grande
Ποσότητα καυτού νερού ανά κούπα
Množství horké vody na džbánek
Ilość wody gorącej na kubek
Cantitatea apă fierbinte per cană
Количество горячей воды на кружку
Bir mağara için sıcak su miktarı
每大杯熱水份量

大カップ一杯当りの熱湯の量
머그컵당 더운물의 량

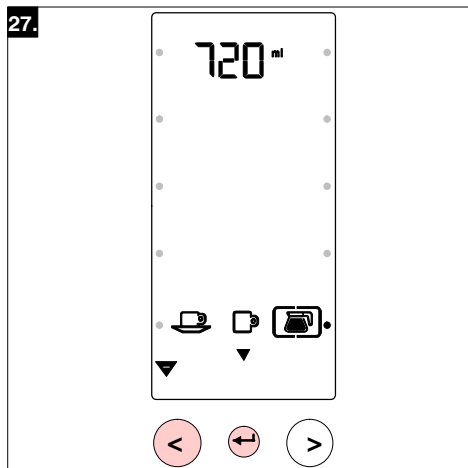

☒ ☐ ————— ■
off 20 720

Amount of hot water per decanter
Quantité d'eau chaude par pichet
Füllmenge Kanne Heißwasser
Doseergrootte kan heet water
Kvantitet hetvatten/kanna
Mengde varmt vann pr. kanne
Mængde af varmt vand pr. kande
Kuuman veden määrä / kannu
Dosificación grandeza de jarra de agua caliente
Quantidade de água quente por jarro
Quantità acqua calda per bricco
Ποσότητα καυτού νερού ανά κανάτα
Množství horké vody na konvici
Ilość wody gorącej na dzbanek
Cantitatea de apă fierbinte per bol
Количество горячей воды на графин
Bir pot için sıcak su miktarı
每壺熱水份量

デカンター一杯当りの熱湯の量
디켄터당 더운물의 량

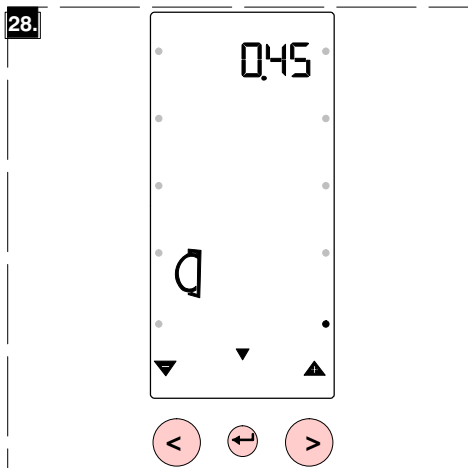

Price-fixing hot water
Indice prix eau chaude
Preis Heißwasser
Prijstelling heet water
Bestäm pris på vatten
Satt pris varmt vann
Pris indstilling varmt vand
Hinnan säättö kuuma vesi
Regulación de agua caliente
Atribuir preço água quente
Prezzo acqua calda
Ρυθμιστής τιμής καυτού νερού
Programování ceny horké vody (čaje)
Ustawianie ceny (wrzatkę)
Cotă apă fierbinte stabilită in preț
Цена воды
Sıcak su ücret sabitleme
熱水定價

価格設定された熱湯
고정가격(더운물)

P

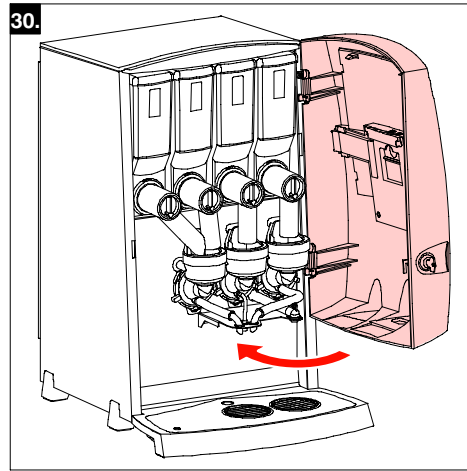
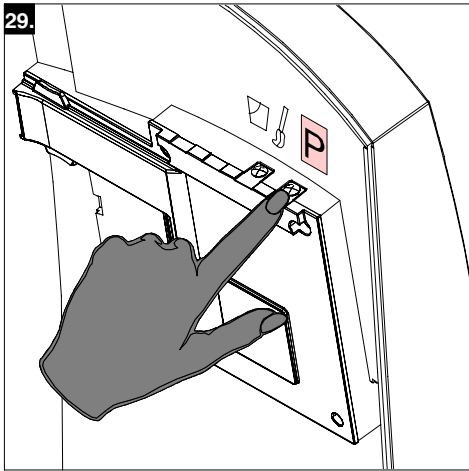

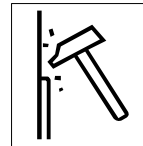

Descaling
Détartrage
Entkalkung
Ontkalken
Avkalkning

Rensing
Afkalkning
Kalkinpoisto
Descalcificaci3n
Descalcificac3o

Decalcificazione
Αφαλάτωση
Odv3pn3n3
Odkamienianie
Decalcarizare

УИСТКА ОТ НАКИПИ
Kireçten arındırma
除垢
デスケール
스케일 청소

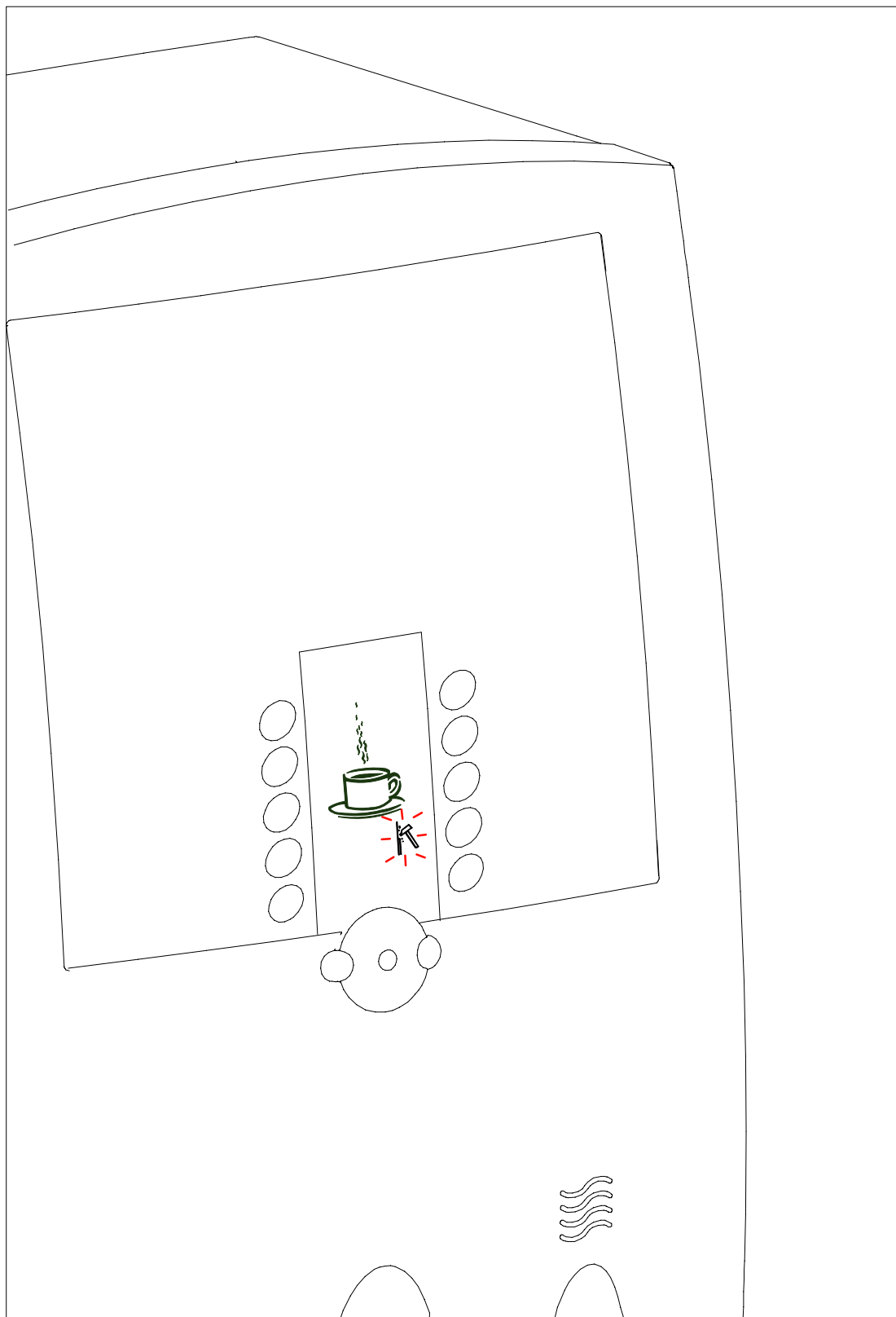

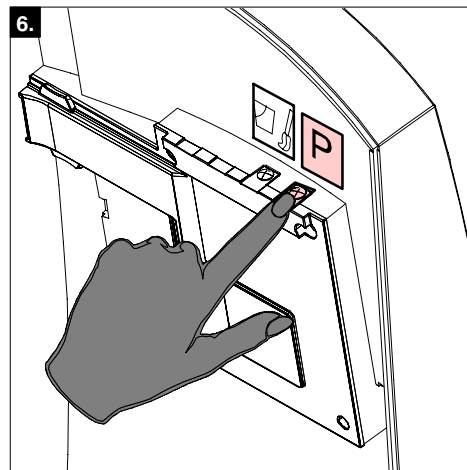
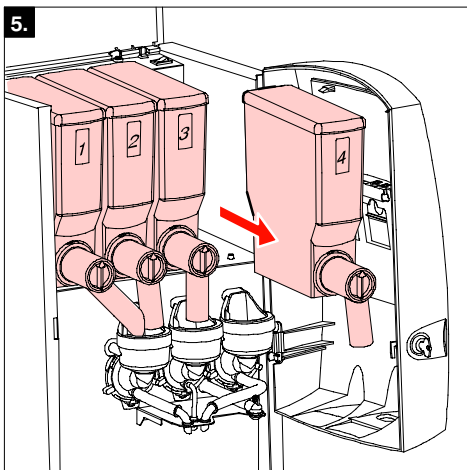
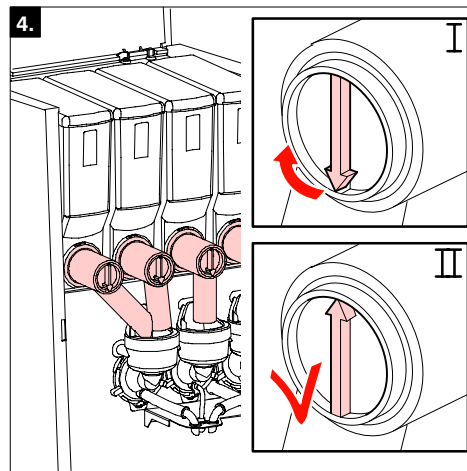
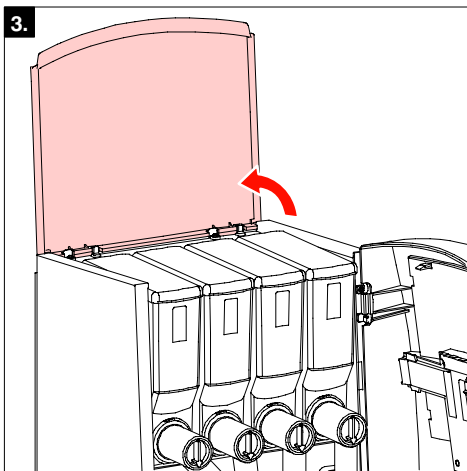
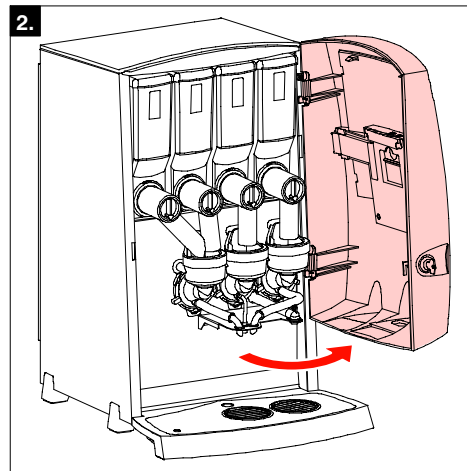
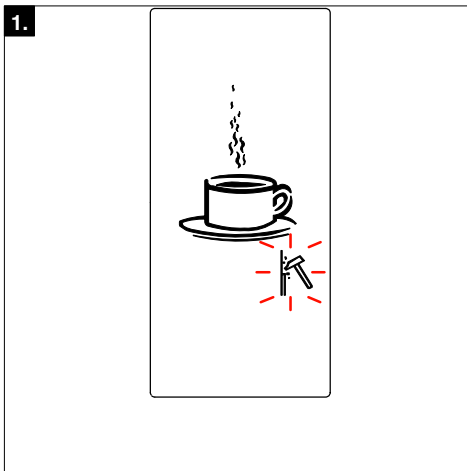

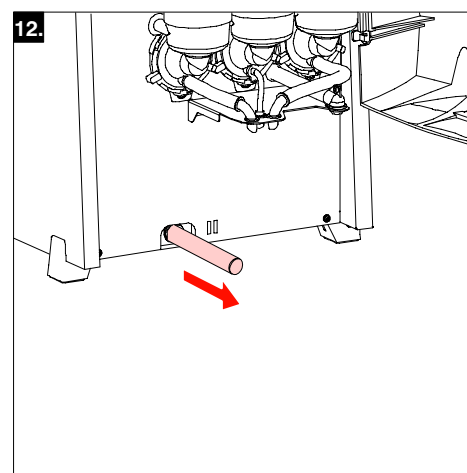
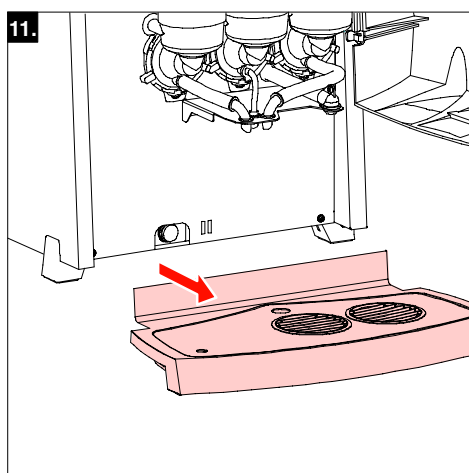
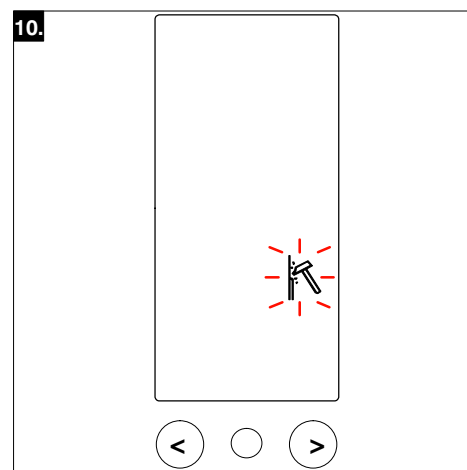
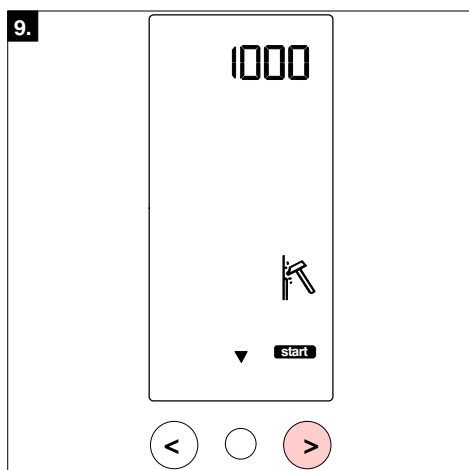
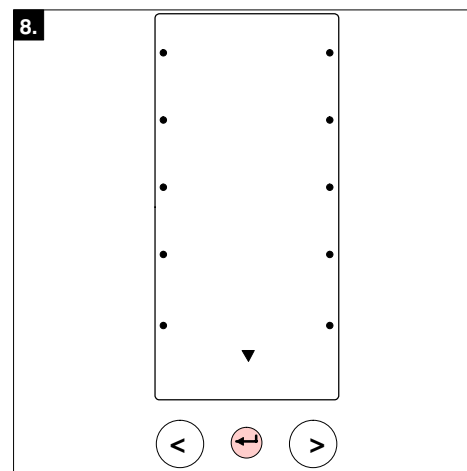
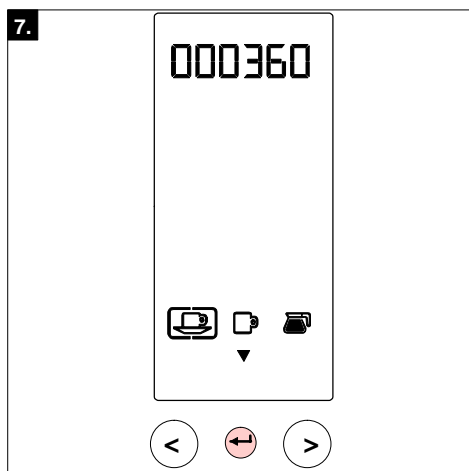
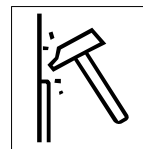

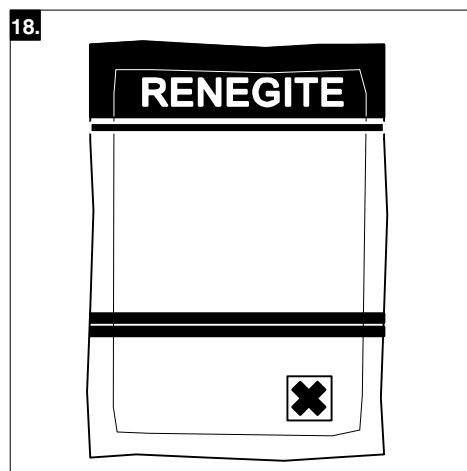
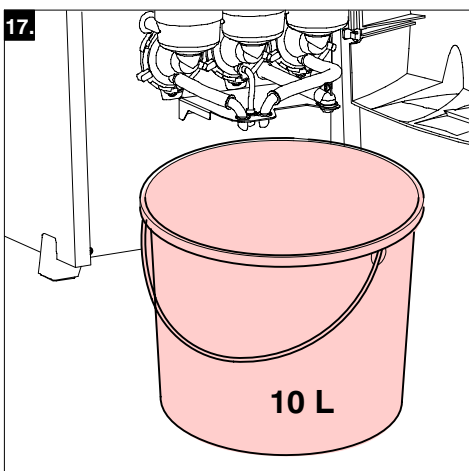
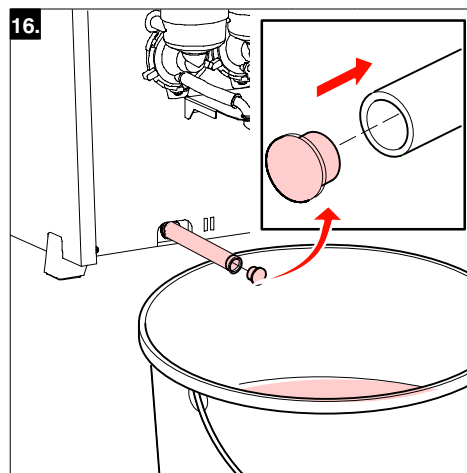
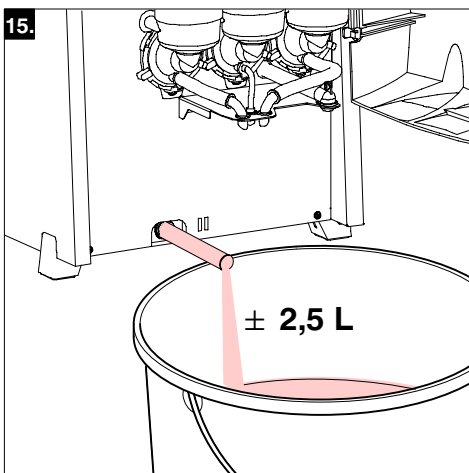
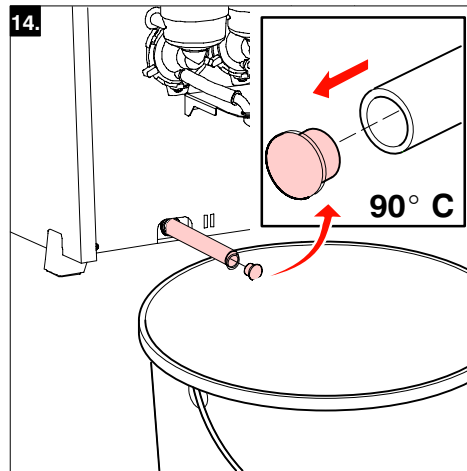
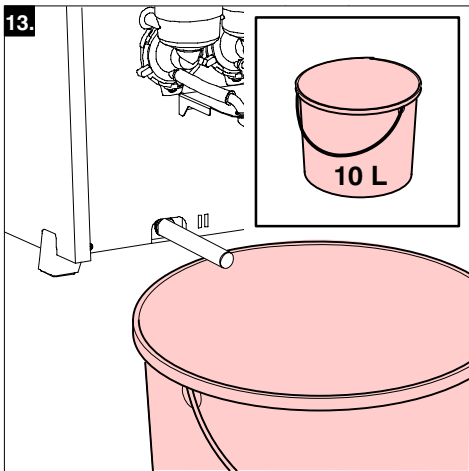
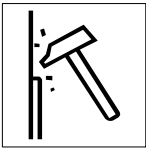

700.403.347

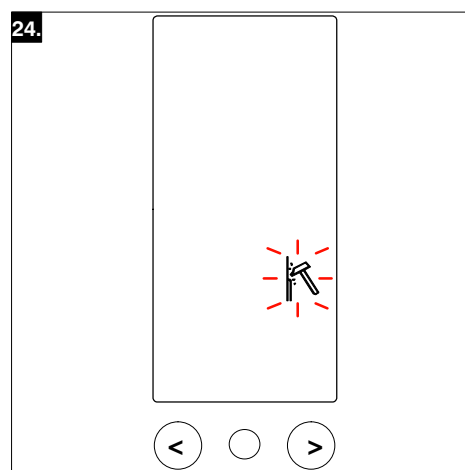
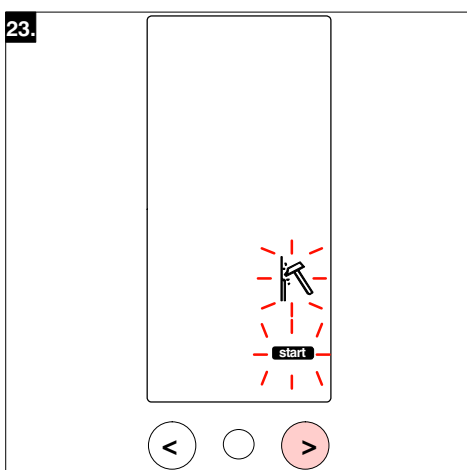
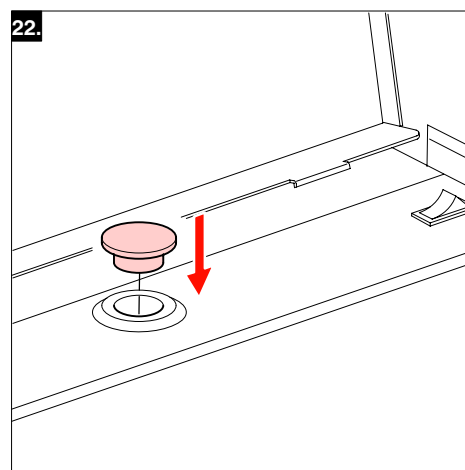
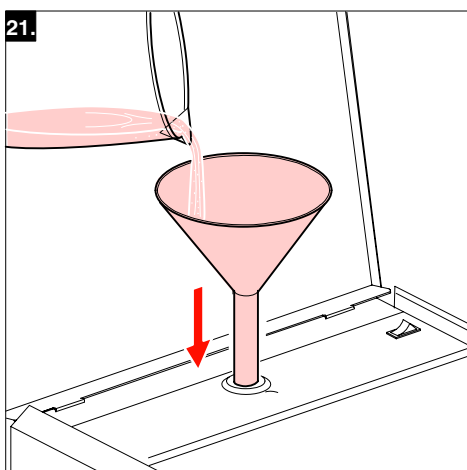
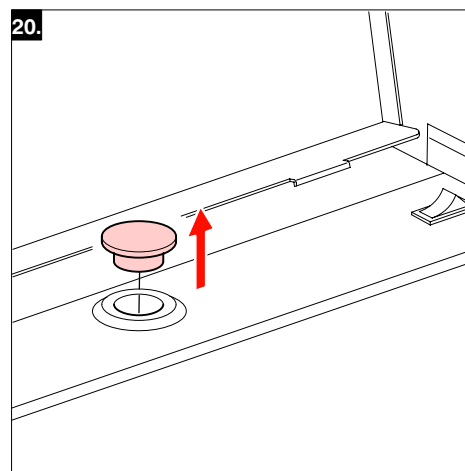
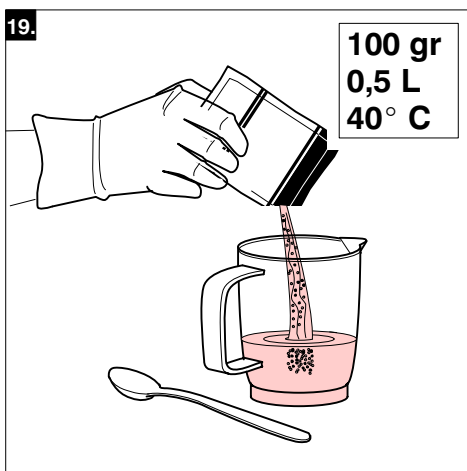
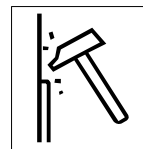

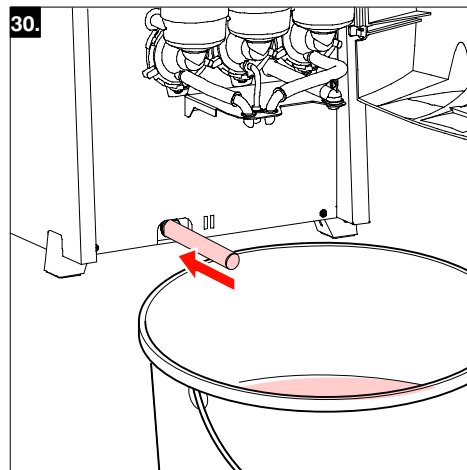
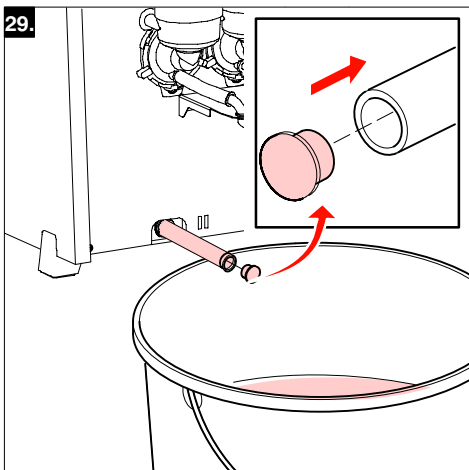
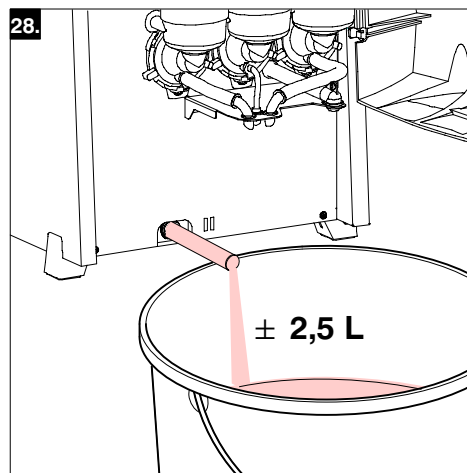
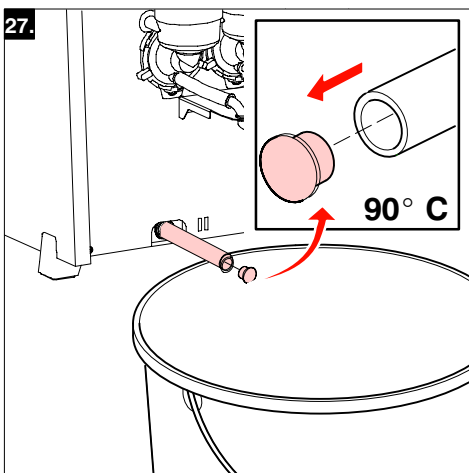
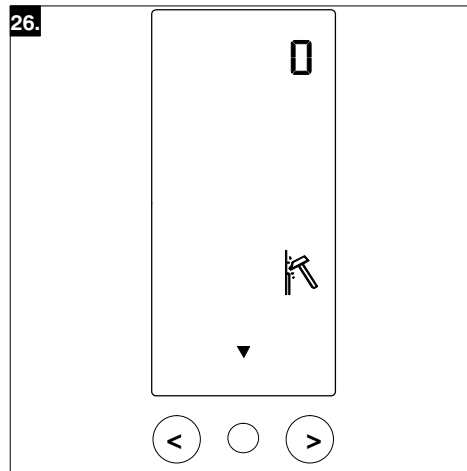
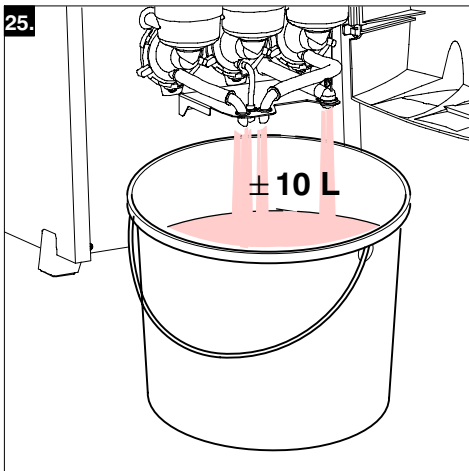

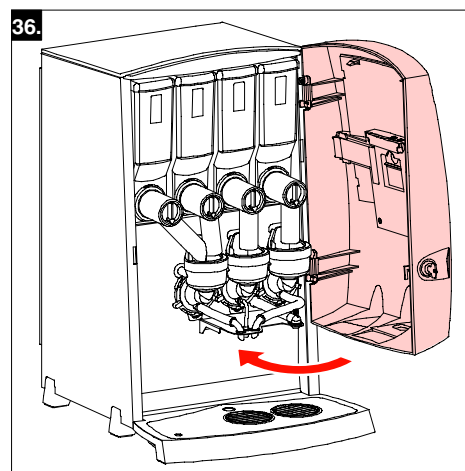
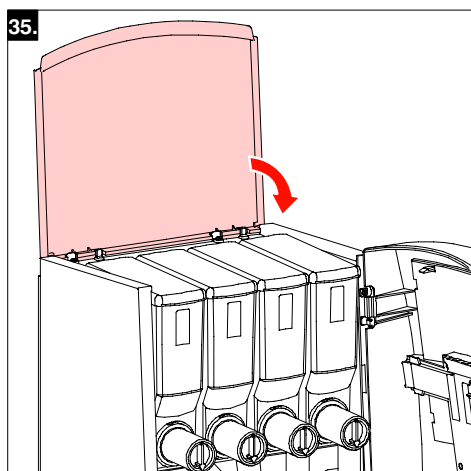
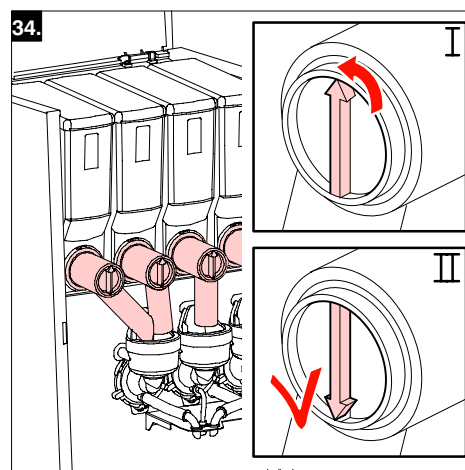
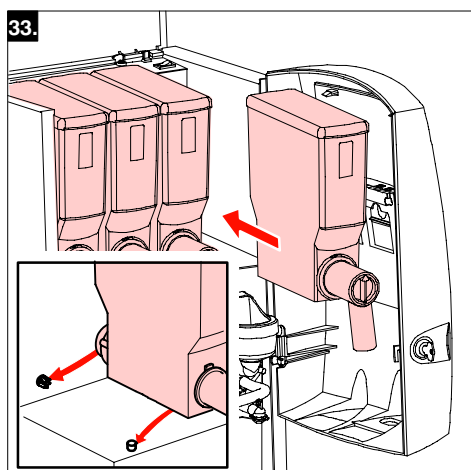
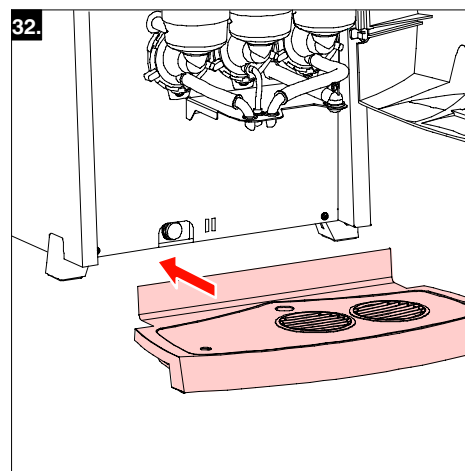
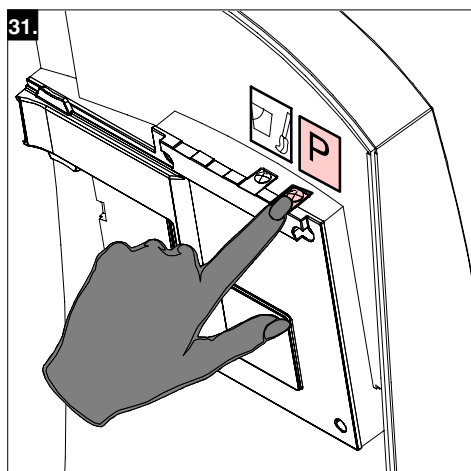
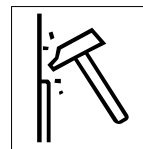

Head office

Bravilor Bonamat BV

Adress : Pascalstraat 20
P.O.Box : 188
1700 AD Heerhugowaard
The Netherlands
Tel. : + 31 (0)72 57 51 751
Fax : + 31 (0)72 57 51 758
e-mail : sales@bravilor.com

Bonamat GmbH

Adress : Brookstiege 14
22145 Stapelfeld
Deutschland
Tel. : (040) 60 823-0
Fax : (040) 60 823-100
E-mail : info.de@bonamat.com

Bravilor Ltd

Adress : Unit 15 Cordwallis Park
Clivemont Road, Maidenhead
Berkshire SL6 7BU
United Kingdom
Tel. : (01628)- 776060
Fax : (01628) - 776035
E-mail : enquiries@bravilor.com

Bonamat Norge AS

Adress : Kallerudlia 11
Postboks: 60
2801 Gjøvik
Norge
Tel. : 61 13 09 65
Fax : 61 13 09 75
E-mail : info.no@bonamat.com

Bonamat AB.

Adresse : Viggbyholmsvägen 83
18377 Täby
Sverige
Tel. : 08-622 64 50
Fax : 08-622 58 70
E-mail : info.se@bonamat.com

Bravilor Belux N.V.

Adress : Boomgaardreef 7
2900 Schoten
Belgique / België
Tel. : (03) 663.77.22
Fax : (03) 663.77.44
E-mail : info.be@bravilor.com

Bravilor France S.A.S.

Adresse : 5, Rue Michel Carré
B.P. : N° 34
95102 Argenteuil Cedex
France
Tél. : 01.34.34.47.74
Fax : 01.34.34.47.75
E-mail : info.fr@bravilor.com



Italiano
Ελληνικά
Česky
Polski
Română

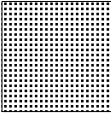

Русский
Türkçe
中文
日本語
한글

Informazione Πληροφορίες Informace Informacja Informație		Информация Bilgi 資料 情報 알림
Indice Περιεχόμενα Obsah Spis treści Index		Содержание İçindekiler 内容目録 目次 북차
Installazione Εγκατάσταση Instalace Instalacja Operare		Установка Yerleştirme 安裝 設置 설치
Decalcificazione Αφαιμάτωση Odvápnění Odkamienianie Decalcarizare		уистка от накипи Kireçten arındırma 除垢 데스케일 스케일 청소
Programmazione Προγραμματισμός λειτουργίας Programování Programowanie Programare		Программирование Programlama 程式 プログラミング 프로그래밍
Prescrizioni di sicurezza Έντυπο ασφαλείας Bezpečnostní kniha Wskazówki bezpieczeństwa Carte instructaj	 700.403.347	Инструкция по эксплуатации Güvenlik kitabı 安全冊子 安全說明書 안전 지침서
Manuale per l'utente Εγχειρίδιο χρήσης Provozní příručka Instrukcja obsługi Manualul utilizatorului	 700.403.355	Руководство по пользователю Kullanıcı kılavuzu 使用者手冊 ユーザーマニュアル 카트리지

Elenco prodotti Πίνακας συστατικών Přehled směsí Lista skłódników Listă ingrediente		Список ингредиентов İçindekilerin listesi 成份清單 材料リスト 원재료 목록
Attendere Αγαμονή Čekejte Czekaj Așteaptă		Ждите Bekle 等候 待つ 기다림
Guanti di protezione Γάντια ασφαλείας Ochranné rukavice Rękawiczki ochronne Mănuși protecție		Защитные перчатки Güvenlik eldivenleri 安全手套 安全手袋 안전용 장갑
Occhiali di protezione Γυαλιά ασφαλείας Ochranné brýle Okulary ochronne Ochelari protecție		Защитные очки Güvenlik gözlükleri 護目鏡 安全眼鏡 안전용 안경
Liquido caldo Καυτό υγρό Horký nápoj Gorący płyn Lichid fierbinte		Горячая жидкость Sıcak sıvı 熱液體 熱水 더운 용액
Contatore Μετρητής Počítadlo Licznik Contor		СРетРик Sayaç 計數器 カウンタ 카운터
Accessori Εξαρτήματα Příslušenství Akcesoria Accesorii		Аксессуары Aksesuarlar 附件 備品 악세서리
Opzione Προαιρετικό Nepovinný Opcja Opțional		Необязательный Opsiyonel 選擇 オプション 선택 사양



**/// BRAVILOR
BONAMAT**

© 03-2004

700.403.363