

1



E



User manual
Mode d'emploi Utilisateur
Gebraucher Handbuch
Gebruiksaanwijzing
Användarmanualen
Brukerhåndbok
Brugsanvisningen
Käyttäjän käsikirja
Manual del usuario
Manual do utilizador
Manuale per l'utente
Εγχειρίδιο χρήσης
Prostudujte uživatelskou
Podręcznik użytkownika
Manualul utilizatorului
уководство пользователя
Kullanıcı kılavuzu
使用者手冊
ユーザーマニュアル
사용자 설명서

NESCAFÉ®
KOMO v2.0



English
Français
Deutsch
Nederlands
Svenska

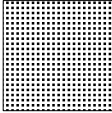

Norsk
Dansk
Suomi
Español
Português

Information Information Information Informatie Information		Informasjon Information Informaatio Información Informação
Table of contents Table des matières Inhaltsangabe Inhoudsopgave Innehållsförteckning		Innholdsfortegnelse Indholdsfortegnelse Sisällysluettelo Contenido Índice
Handling Fonctionnement Bedienung Bedienen Handhavande		Betjene Betjening Käsittely Operación Execução
Selection button Touches de sélection Wahltaste Keuzetoets Väljarknapp		Velgerknapp Valg knap Valintanappi Tecla de selección Botão de selecção
Fill / empty Remplissage / vidange Füllen / Entleeren Vullen / legen Påfyllning / tömning		Fyll / Tøm Fuld / Tom Täyttö / tyhjennys Llenar / vaciar Cheio / vazio
Cleaning Nettoyage Reinigung Schoonmaken Rengöring		Vasking Rengøring Puhdistus Limpiar Limpeza
Cleaning, daily Nettoyage quotidien Reinigung, täglich Schoonmaken, dagelijks Daglig rengöring		Daglig vask Rengøring, daglig Päivittäinen puhdistus Limpeza diaria Limpeza diária
Cleaning, weekly Nettoyage hebdomadaire Reinigung, wöchentlich Schoonmaken, wekelijks Vecko rengöring		Ukentlig vask Rengøring, ugentlig Viikoittainen puhdistus Limpeza semanal Limpeza semanal

Cartridge Cartouche Kartusche Cartridge Patron		Kasset Patron Kasetti Cartucho Cartucho
Canister Bac produit Kanister Canister Kanister		Kanister Beholder Kanisteri Contenedor de producto Depósito
Water Eau Wasser Water Vatten		Vann Vand Vesi Água Água
Mixing system Mélangeur Mischsystem Mixsysteem Blandnings system		Miksesystem Mixer system Sekoitusjärjestelmä Sistema de mezclar Sistema de mistura
Ventilation system Système de ventilation Abluftsystem Ventilatiesysteem Ventilationssystem		Viftesystem Ventilationssystem Ilmastointijärjestelmä Sistema de ventilación Sistema de ventilação
Drip-tray Egouttoir Tropfschale Lekbak Spillbricka		Spillbrett Drypbakke Tippa-allas Escurridero Tabuleiro
Messages Messages Meldungen Meldingen Meddelanden		Meldinger Beskeder Viestit Mensajes Mensagens





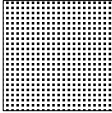

it : Per la Sua lingua consultare la fine di questo documento.
 el : Στην αναδιπλωμένη σελίδα, στο τέλος του εντύπου, μπορείτε να κοιτάξετε για τους όρους στη γλώσσα σας.
 cz : Volba jazyka je popsána na konci následující stránky tohoto návodu.
 pl : Szukaj swojego języka na ostatnich stronach dokumentu.
 ro : Citiți pentru limba dvs pagina atașată la spatele acestui document.
 ru : Вкладыш на Вашем языке в конце этого документа.
 tr : Diliniz için arkadaki katli sayfaya bakınız.
 ch : 查看背頁的所屬語文
 jp : 各言語についてはこの説明書の最後のページをご参照ください。
 kor : 자료의 뒷면 집은페이지에서 해당언어를 참조 하시오





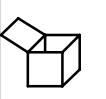

English
Français
Deutsch
Nederlands
Svenska



Norsk
Dansk
Suomi
Español
Português

Safety book Sommaire des sécurités Sicherheitsvorschriften Veiligheidsboek Säkerhetsföreskrifter	 700.403.347	Sikkerhetsbok Sikkerhedsbog Turvallisuusohjeet Libro de seguridad Instruções de segurança
Installation and maintenance manuall Manuel pour l'installation et l'entretien Installations und Wartungs Handbuch Installatie en onderhouds- handboek Installation och underhålls manual	 700.403.459A	Installasjons og vedlikeholdsmanual Installation og vedligeholdelses manual Asennus- ja ylläpitökäyttöohje Manual de instalación y mantenimiento Manula de Instalação e Manutenção
Accessories Accessoires Zubehör Toebehoren Tillbehör		Tilbehør Valgbar Lisälaitteet Accesorios Acessórios
Wait Patienter Warten Wachten Vänta		Vent Vent Odota Esperar Aguardar
Brush Brosse Pinsel Kwast / Borstel Borste		Kost Børste Harjaa Sepillar Escova
Moist cloth Chiffon humide Feuchtes Tuch Vochtige doek Fuktig trasa		Fuktig klut Fugtig klud Kostea pyyhe Trapo húmedo Pano húmido
Rinse Rincer Spülen Afspoelen Sköljning		Skylle Rensning Huuhtelee Aclarar Enxaguamento

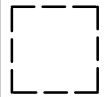
Detergent Détergent Spülmittel Afwasmiddel Rengöringsmedel		Vaskemiddel Rengøringsmiddel Puhdistusaine Detergente Detergente
Dishwasher proof Lave-vaisselle autorisé Geschirrspülertauglich Vaatwasmaschinebestendig Tål maskindisk		Tåler oppvaskmaskin Maskinopvaske bestandig Astianpesukoneen kestävä Rest. para lavaplatos À prova de máquina de lavar louça
Energy-saving mode Mode économique Energiesparen Energiesparend Energisparläge		Energisparing Energi spare funktion Sähköä säästävä Posición economía Modo de economia de energia
Call distributor Appelez votre distributeur Händler anrufen Verkoopkantoor bellen Ring Leverantör		Ring leverandør Tilkald forhandler Soita jälleenmyyjälle Llame al distribuidor Contacto importador
Descaling Détartrage Entkalkung Ontkalken Avkalkning		Rensing Afkalkning Kalkinpoisto Descalcificación Descalcificação
Optional Option Produktliste Optioneel Tillval		Valgfri Tilbehør Valinnainen Opcional Opcional



1.



2.



2a



2b

3.

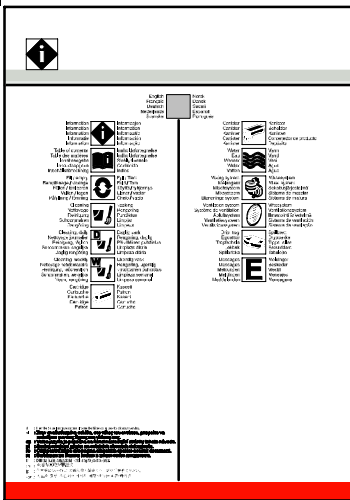

4.

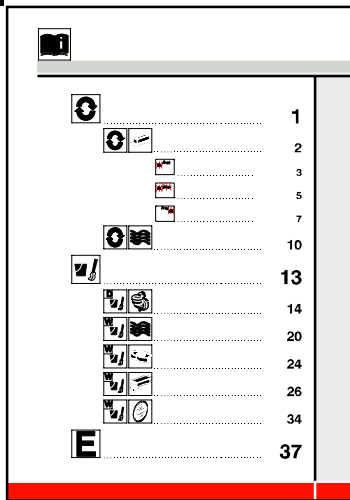

5.

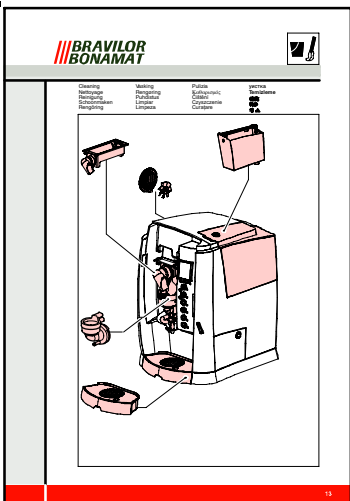

6.

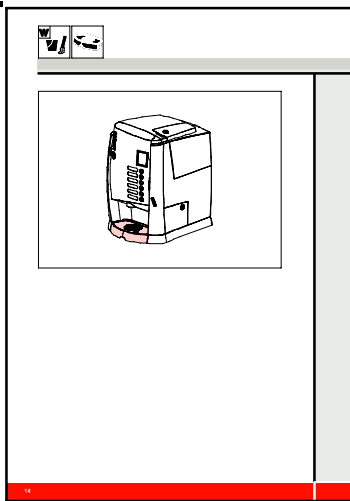

7.

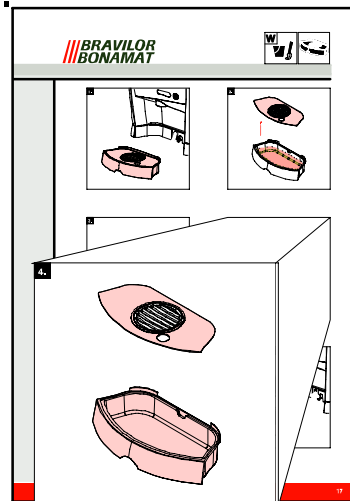

8.



**GB****This manual is set up with pictures.**

Reason: language independent; unambiguous; compact!
How to use this manual?

***) The numbers 1 till 8 refer to the pictures on the previous page.**

1. First read the safety instructions (700.403.347).
 2. Then read the user manual (2a) or operator manual (2b).
 3. Study all pictograms and read their meaning.
 4. Find the correct chapter and section in the index.
- Chapter structure:*
5. Chapter with the subjects (red).
 6. Section with the subjects (red).
 7. Instruction pages with actions (red) and pictograms (comments/prohibitions) underneath the pictures.
 8. First read the complete instruction page, then carry out the actions (red).

FR**Ce manuel est composé d'images.**

Raison : pas de problème linguistique; aucune ambiguïté ; compact !

Comment utiliser ce manuel ?

***) Les numéros 1 à 8 renvoient aux images de la page précédente.**

1. Tout d'abord lire mises en gardes et les directives–de sécurité (700.403.347)
 2. Ensuite lire le manuel de l'utilisateur (2a) ou de l'opérateur (2b).
 3. Etudier tous les pictogrammes et lire leur signification.
 4. Rechercher dans l'index le chapitre et le paragraphe exact.
- Structure du chapitre :*
5. Chapitre avec le thème abordé (rouge).
 6. Paragraphe du chapitre avec le sous-thème abordé (rouge).
 7. Page d'instructions avec les opérations à effectuer (rouge) et les petits pictogrammes (obligations/interdictions) sous les images.
 8. Tout d'abord lire la totalité des instructions, puis exécuter les opérations à effectuer (rouge).

DE**Dieses Handbuch ist mit Abbildungen aufgebaut.**

Grund: Sprache unabhängig; Eindeutig; Kompakt!
Wie wende ich dieses Handbuch an?

***) Die Nummern 1 bis 8 verweisen zu den Bildern auf die vorhergehende Seite.**

1. Lesen Sie zuerst die Sicherheitsbestimmungen (700.403.347).
 2. Lesen Sie dann das Gebraucher Handbuch (2a) oder Installations und Wartungs Handbuch (2b).
 3. Studieren Sie alle Pictogramme und lesen Sie Ihre Bezeichnung.
 4. Suchen Sie im Index das richtige Kapitel und den Paragraphen.
- Aufbau Kapitel:*
5. Kapitel mit dem Thema (Rot).
 6. Paragraph mit dem Thema (Rot).
 7. Instruktionseite mit Handlungen (Rot) und Pictogrammen (Gebote/Verbote) unter der Zeichnung.
 8. Lesen Sie zuerst die ganze Instruktionseite und führen Sie danach die Handlungen (Rot) durch.

NL**Deze handleiding is opgebouwd uit plaatjes.**

Reden: taalonaafhankelijk; eenduidig; compact!
Hoe moet ik deze handleiding gebruiken?

***) De nummers 1 t/m 8 verwijzen naar de plaatjes op de voorgaande pagina.**

1. Lees eerst de veiligheidsvoorschriften (700.403.347)
 2. Lees dan de 'user manual' (2a) of 'operator manual' (2b).
 3. Bestudeer alle pictogrammen en lees hun betekenis.
 4. Zoek in de index het juiste hoofdstuk en paragraaf op.
- Opbouw hoofdstuk:*
5. Hoofdstuk met de onderwerpen (rood).
 6. Paragraaf met het onderwerp (rood).
 7. Instructiepagina's met handelingen (rood) en pictogrammen (geboden/verboden) onder de tekening.
 8. Lees eerst de gehele instructiepagina en voer daarna de handelingen (rood) uit.

Denna manual är sammanställd av bilder.

Orsak: oberoende av språk; tydlig; kompakt!
Hur ska manualen användas?

***) Siffrorna 1 till 8 hänvisar till bilderna på föregående sida.**

1. Läs först säkerhetsinstruktionerna (700.403.347).
 2. Läs därefter användarmanualen (2a) eller driftmanualen (2b).
 3. Studera bildtecknen och förstå deras betydelse.
 4. Leta efter rätt kapitel och avsnitt i innehållsförteckningen.
- Kapitelstruktur:*
5. Kapitel med ämnen (röda).
 6. Avsnitt med ämnen (röda).
 7. Instruktionssidor med åtgärder (röda) och bildtecken (kommentarer/förbud) under bilderna.
 8. Läs först hela instruktionssidan och utför därefter åtgärderna (röda).

SE**Denne håndboken er satt opp med bilder.**

Årsak: Språkuavhengig, entydig, kompakt!

Slik bruker du denne håndboken:

***) Numrene 1 til 8 henviser til bildene på foregående side.**

1. Les først sikkerhetsinstruksjonene (700.403.347).
 2. Les deretter brukerhåndboken (2a) eller operatørhåndboken (2b).
 3. Studer alle piktogrammer og les betydningen av dem.
 4. Finn det riktige kapitlet og avsnittet i stikkordlisten.
- Kapittelstruktur:*
5. Kapittel med emnene (rødt).
 6. Avsnitt med emnene (rødt).
 7. Instruksjonssider med handlinger (røde) og piktogrammer (kommentarer/forbud) under bildene.
 8. Les først hele instruksjonssiden, og utfør deretter handlingene (røde).

NO**Denne vejledning er sat op med billeder.**

Årsag: uafhængig af sprog; utvetydig; kompakt!
Hvordan bruges denne vejledning?

***) Tallene 1 til 8 henviser til billederne på den foregående side.**

1. Læs først sikkerhedsanvisningerne (700.403.347).
 2. Læs derefter brugsanvisningen (2a) eller betjeningsvejledningen (2b).
 3. Studer alle piktogrammer og læs hvad de betyder
 4. Find det rigtige kapitel og afsnit i indekset.
- Kapitlernes opbygning:*
5. Kapitel med emner (rødt).
 6. Afsnit med emner (rødt).
 7. Siderne med anvisninger om de handlinger, der skal udføres (røde), og piktogrammer (bemærkninger/forbud) under billederne.
 8. Læs først hele siden med anvisninger, udfør derefter handlingerne (røde).

DK**Tämä käsikirja perustuu kuvien käyttöön.**

Syy: kielestä riippumaton, yksiselitteinen, kompakt!
Kuinka tätä käsikirjaa käytetään?

***) Numerot 1–8 viittaavat edellisen sivun kuviin.**

1. Lue ensin turvaohjeet (700.403.347).
 2. Lue sitten käyttäjän käsikirja (2a) tai operaattorin käsikirja (2b).
 3. Tutustu kaikkiin piktogrammeihin ja lue niiden merkitys.
 4. Etsi vastaava luku ja kappale hakemistosta.
- Lukujen rakenne:*
5. Luku, jossa on kohteet (punainen).
 6. Kappale, jossa on kohteet (punainen).
 7. Ohjesivut, joilla esitetään toimet (punainen) ja piktogrammit (huomautukset/kiellot) kuvien alla.
 8. Lue ensin ohjesivu kokonaan ja suorita sitten toimet (punainen).

FI

**ES****Este manual se ha elaborado con ilustraciones.**

Motivo: independencia del idioma; nada ambiguo; más compacto!
¿Cómo se utiliza este manual?

***) Los números del 1 al 8 hacen referencia a las ilustraciones de la página anterior.**

1. Lea en primer lugar las instrucciones de seguridad (700.403.347).
2. A continuación, lea el manual del usuario (2a) o el manual del operador (2b).
3. Estudie detenidamente todos los pictogramas y lea su significado.
4. Encuentre el capítulo y la sección correctos en el índice.

Estructura de cada capítulo:

5. Capítulo con los temas (rojo).
6. Sección con los temas (rojo).
7. Páginas de instrucciones con acciones (rojo) y pictogramas (comentarios/prohibiciones) debajo de las ilustraciones.
8. Primero lea completamente la página de instrucciones, luego lleve a cabo las acciones (rojo).

PT**Este manual é composto por imagens.**

Razão: não depende de qualquer idioma; não é ambíguo; compacto!

Como utilizar este manual?

***) Os números de 1 a 8 referem-se às imagens na página anterior.**

1. Leia em primeiro lugar as instruções de segurança (700.403.347).
2. De seguida, leia o manual do utilizador (2a) ou o manual do operador (2b).
3. Estude todos os ícones e leia os seus significados.
4. Procure o capítulo e secção correctos no índice.

Estrutura dos capítulos:

5. Capítulo com o assunto (vermelho).
6. Secção com o assunto (vermelho).
7. Página de instruções com procedimentos (vermelho) e ícones (comentários/proibições) por baixo das imagens.
8. Leia em primeiro lugar a página de instruções completa, e efectue os procedimentos (vermelho).

IT**Il presente manuale è stato realizzato con illustrazioni.**

Motivo: non ha limiti di lingua, è chiaro e compatto.

Consultazione del manuale:

***) I numeri da 1 a 8 fanno riferimento alle immagini sulla pagina precedente.**

1. Leggere prima le norme di sicurezza (700.403.347).
 2. Poi leggere il manuale per l'utente (2a) o il manuale per l'operatore (2b).
 3. Studiare tutti i pittogrammi e leggerne il significato.
 4. Individuare nell'indice il capitolo e la sezione corretti.
- Organizzazione dei capitoli:*
5. Capitolo con i soggetti (rosso).
 6. Sezione con i soggetti (rosso).
 7. Pagine con istruzioni e azioni (in rosso) e pittogrammi (commenti / divieti) sotto le illustrazioni.
 8. Leggere prima tutte le istruzioni e poi eseguire le azioni (in rosso).

EL**Το παρόν εγχειρίδιο αποτελείται από εικόνες.**

Αιτία: ανεξάρτητο από τη γλώσσα, σαφές, μεγάλο μέγεθος!
Πώς θα χρησιμοποιήσετε το εγχειρίδιο :

***) Οι αριθμοί 1 έως 8 αναφέρονται στις εικόνες της προηγούμενης σελίδας.**

1. Διαβάστε πρώτα τις οδηγίες ασφαλείας (700.403.347).
 2. Μετά διαβάστε το εγχειρίδιο χρήσης (2a) ή το εγχειρίδιο χειρισμού (2b).
 3. Μελετήστε όλα τα εικονογράμματα και διαβάστε την ερμηνεία τους.
 4. Βρείτε στο ευρετήριο, το σωστό κεφάλαιο και την ενότητα.
- Δομή κεφαλαίων:*
5. Κεφάλαιο με τα θέματα (κόκκινο).
 6. Ενότητα με τα θέματα (κόκκινο).
 7. Σελίδες με οδηγίες για ενέργειες (κόκκινο) και εικονογράμματα (σχόλια/ απαγορεύσεις) κάτω από τις εικόνες.
 8. Πρώτα διαβάστε ολόκληρη τη σελίδα με τις οδηγίες, και μετά πραγματοποιήστε τις ενέργειες (κόκκινο).

Tato příručka je opatřena obrázky.

Důvod: srozumitelnost bez ohledu na jazyk; jednoznačnost; ucelenost!

Jak tento manuál používat?

***) Čísla od 1 do 8 označují obrázky na předchozí straně.**

1. Nejprve si přečtete bezpečnostní pokyny (700.403.347).
 2. Poté si prostudujte uživatelskou (2a) nebo provozní příručku (2b).
 3. Dále si prostudujte všechny symboly a jejich významy.
 4. V rejstříku vyhledejte příslušnou kapitolu a odstavec.
- Clnění kapitol:*
5. Kapitola venovaná tématu (červené označení).
 6. Odstavec venovaný tématu (červené označení).
 7. Instrukční stránky se znázorněnými postupy (červené označení) a symboly (poznámky/zákazy) uvedenými pod obrázky.
 8. Nejprve si přečtete celou instrukční stránku a poté proveďte potřebné úkony (červené označení).

CZ**Niniejszy podręcznik składa się z rysunków.**

Powód: jest czytelny niezależnie od wersji językowej; jednoznaczny; zwięzły!

Jak korzystać z podręcznika?

***) Numery od 1 do 8 dotyczą rysunków na poprzedniej stronie.**

1. Najpierw zapoznaj się z instrukcjami bhp (700.403.347).
 2. Następnie przeczytaj podręcznik użytkownika (2a) lub instrukcję obsługi (2b).
 3. Zapoznaj się z wszystkimi piktogramami i ich znaczeniem.
 4. Znajdź właściwy rozdział i część w indeksie.
- Struktura rozdziału:*
5. Rozdział z tematami (zaznaczony na czerwono).
 6. Część z tematami (zaznaczona na czerwono).
 7. Strony z instrukcjami dotyczące działania (zaznaczone na czerwono) i piktogramy (uwagi/zakazy) pod rysunkami.
 8. Najpierw zapoznaj się z wszystkimi instrukcjami, a następnie wykonaj czynności (zaznaczone na czerwono).

PL**Acest manual este compus din imagini.**

Motivul: independent de limbă; fără echivoc; compact!

Cum se utilizează acest manual?

***) Numerele de la 1 până la 8 se referă la imaginile de pe pagina anterioară.**

1. Mai întâi citiți instrucțiunile de siguranță (700.403.347).
 2. Apoi citiți manualul utilizatorului (2a) sau manualul operatorului (2b).
 3. Studiați toate pictogramele și citiți semnificația acestora.
 4. Căutați capitolul și paragraful corect în cuprins.
- Structura capitolului:*
5. Capitolul cu teme principale (roșu).
 6. Paragraful cu teme principale (roșu).
 7. Paginile de instrucțiuni cu acțiunile care trebuie întreprinse (roșu) și pictograme (comentarii/interdicții) sub imagini.
 8. Mai întâi citiți toată pagina de instrucțiuni, apoi executați acțiunile (roșu).

RO**Настоящее Руководство выполнено в виде рисунков.**

Преимущества такого представления: независимость от знания языка однозначность, компактность.

Как пользоваться Руководством:

***) В Пунктах 1–8 даны пояснения к рисункам, приведенным на предыдущей странице.**

1. Внимательно изучите Инструкции по безопасности (700.403.347).
 2. Изучите Рководство пользователя (2a) или Рководство оператора (2b).
 3. Внимательно изучите все пиктограммы и их значения.
 4. Найдите в указателе нужные главу и раздел.
- Структура главы:*
5. Глава с изображением блоков (Выделены красным цветом).
 6. Раздел с изображением блоков (Выделены красным цветом).
 7. Страницы, содержащие инструкции с указанием действий (Выделены красным цветом) и пиктограммы (комментарии / заиреты) под рисунками.
 8. Прежде всего внимательно просмотрите всю страницу с инструкциями, затем выполняйте действия (Выделены красным цветом).

RU

**TR**

Bu kılavuz resimli olarak hazırlanmıştır.

Sebepler: dilden bağımsızlık; net anlaşılabilirlik; kısalık!
Bu kılavuzu nasıl kullanmalı?

***) 1 ile 8 arasındaki sayılar önceki sayfadaki resimleri gösterir.**

1. Önce güvenlik talimatlarını okuyun (700.403.347).
2. Sonra kullanıcı kılavuzu (2a) veya operatör kılavuzunu(2b) okuyun.
3. Tüm semboller ve anlamlarını inceleyin.
4. Dizinde uygun kısmı ve bölümü bulun.

Kısım yapısı:

5. Konulara göre kısımlar (kırmızı).
6. Konulara göre bölümler (kırmızı).
7. Resimlerin altında işlemler (kırmızı) ve semboller (notlar/uyarılar) olan talimat sayfaları.
8. Önce talimat sayfasının tamamını okuyun, sonra işlemleri (kırmızı) uygulayın.

CH

本手冊包括圖片。

理由：獨立於語言；毫不含糊；簡潔有力！
如何使用本手冊？

***) 數字1-8指的是前一頁上的圖片。**

1. 首先閱讀安全說明（700.403.347）。
2. 然後閱讀使用者手冊（2a）或操作手冊（2b）。
3. 研究所有的圖片，閱讀其意義。
4. 在索引中找到正確的章節。

章節結構：

5. 帶有主題的章（紅色）。
6. 帶有主題的節（紅色）。
帶有動作的說明頁面（紅色）和圖片下面的圖示（備註/禁止事項）。
8. 首先閱讀完整的說明頁面，然後執行動作（紅色）。

このマニュアルはイラストで構成されています。

その理由：言語を選ばない；明白；コンパクト！

このマニュアルの使い方

***) 1から8は前ページのイラストを参照して下さい。**

1. 最初に安全上の注意をお読み下さい。（700.403.347）。
2. 次にユーザーマニュアル(2a)または操作マニュアルをお読み下さい(2b)。
3. 全ての絵文字の意味について学び、その意味を理解して下さい。
4. 探している章とセクションを目次から見つけて下さい。

章の構成：

5. 章と主題(赤)。
6. セクションと主題(赤)。
7. イラストの下に行動指示(赤)と絵文字(コメント/禁止事項)を示したインストラクションページ
8. 最初にインストラクションページを最後まで読み、行動指示に従って下さい。(赤)

이 설명서는 그림과 함께 구성됩니다.

이유：언어설명을 보다 더 정확하게 해 줍니다；
애매하지 않고 간결하게 합니다.

설명서를 어떻게 사용합니까？

***) 1번부터 8번까지는 전 페이지의 그림에 관해 언급한 것입니다.**

1. 먼저 안전에 관한 소개를 읽으십시오.(700.403.347)
2. 그런 다음 사용자 설명서(2a)와 작동자 설명서(2b)를 읽어보십시오.
3. 모든 픽토그램을 숙지하고, 의미를 이해하십시오.
4. 색인에서 알맞는 장(chapter)과 과(section)를 찾으십시오.

장(chapter) 구성：

5. 주제별 장(붉은색)
6. 주제별 과(붉은색)
7. 그림 하부에 있는 작동(붉은색)과 픽토그램(의견/금지사항)에 관한 소개 페이지
8. 먼저 소개 페이지를 모두 읽으신 후, 작동을 실행하십시오.(붉은색)

JP**KO**

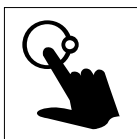

Handling
Fonctionnement
Bedienung
Bedienen
Handhavande

Betjène
Betjening
Käsittely
Operación
Execução

Istruzione d'uso
Χειρισμός
Obsluha
Instrukcja obsługi
Instalare

Обслуживание
Kullanım
操作
取り扱い
취급

1



3



4



5

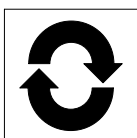

Fill / empty
Remplissage / vidange
Füllen / Entleeren
Vullen / legen
Påfyllning / tömning . . .

Fyll / Tøm
Fuld / Tom
Täyttö / tyhjennys
Llenar / vaciar
Cheio / vazjo

Riempire / scaricare
Ενδειξη γεμάτο /
Αδειο
Plný / prázdny
Pełny / pusty
Plin / Gol

Наполнить / опорожнить
Doldurma / Boşaltma
満/空
給水・空にする
채움/털빈

7

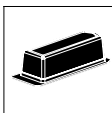
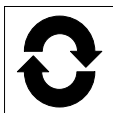

8



9



11

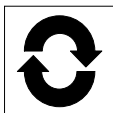

14

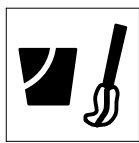

Cleaning
Nettoyage
Reinigung
Schoonmaken
Rengöring

Vasking
Rengøring
Puhdistus
Limpiar
Limpeza

Pulizia
Καθαρισμός
Čištění
Czyszczenie
Curățare

уистка
Temizleme
清洗
洗淨
청소

17

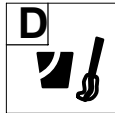

18

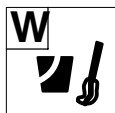

24



28

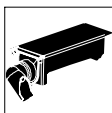

30

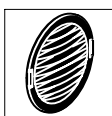
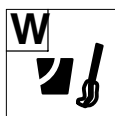

38

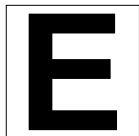

Messages
Messages
Meldungen
Meldingen
Meddelanden

Meldinger
Beskeder
Viestit
Mensajes
Mensagens

Messaggio
Μηνύματα
Zprávy
Wiadomości
Mesaje

Сообщения
Mesajlar
信息
メッセージ
메세지

41





Handling
Fonctionnement
Bedienung
Bedienen
Handhavande

Betjene
Betjening
Käsittely
Operación
Execução

Istruzione d'uso
Χειρισμός
Obsluha
Instrukcja obsługi
Instalare

Обслуживание
Kullanım
操作
取り扱い
취급

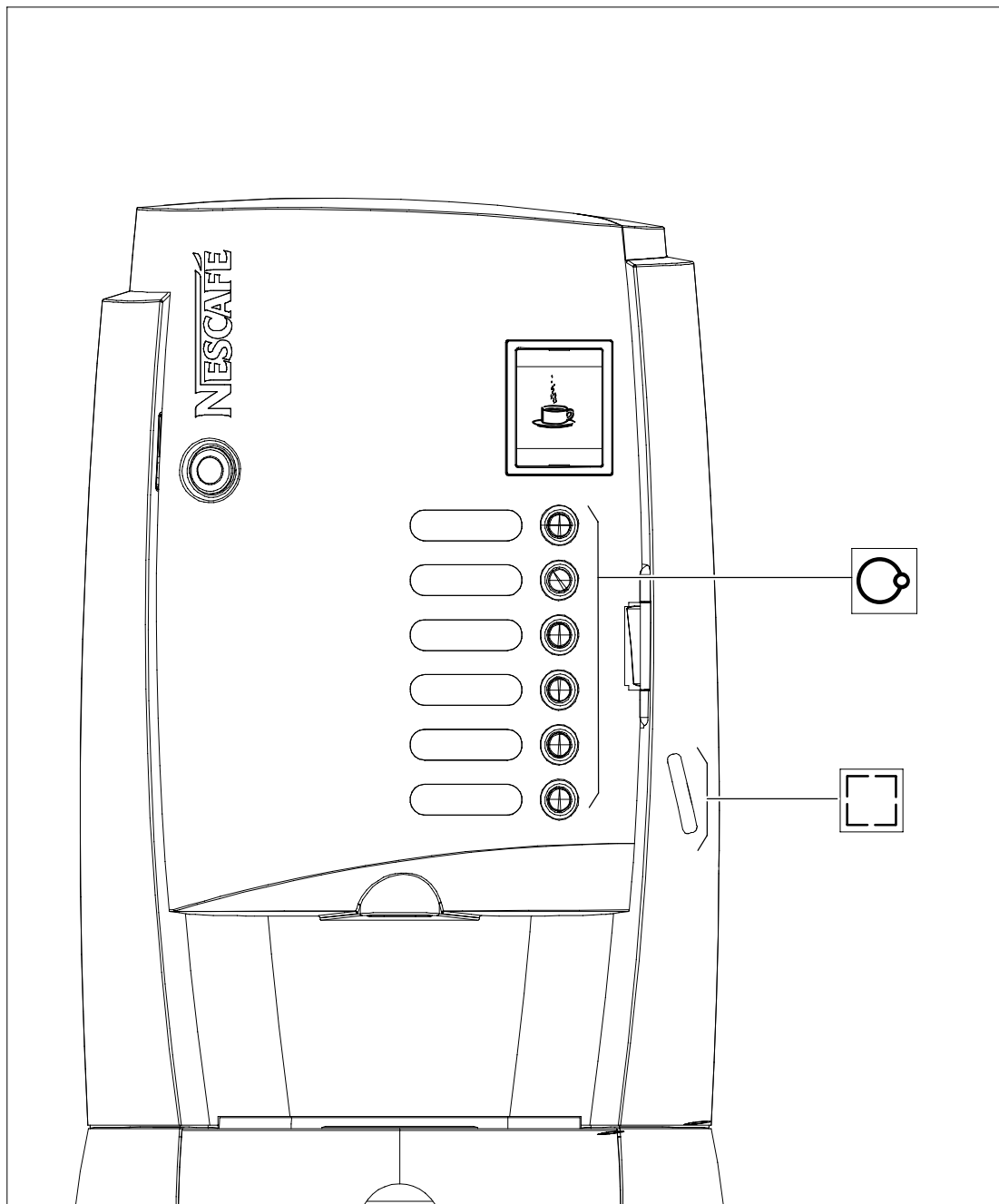

700.403.347

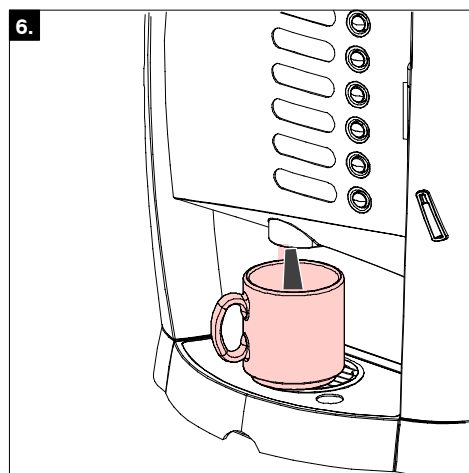
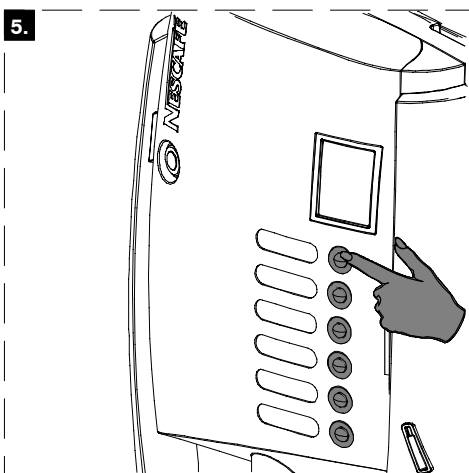
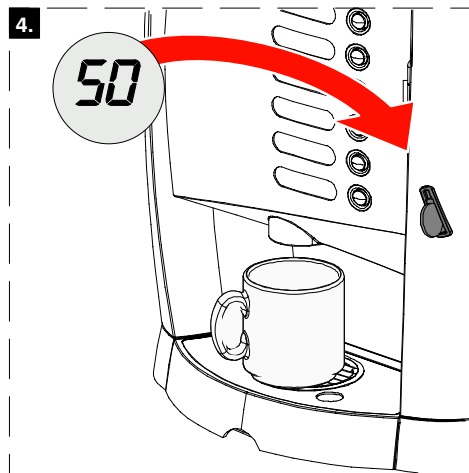
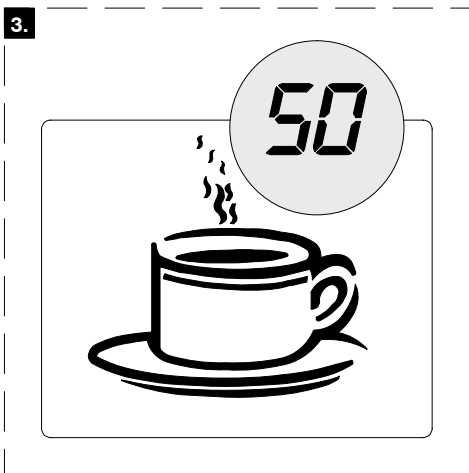
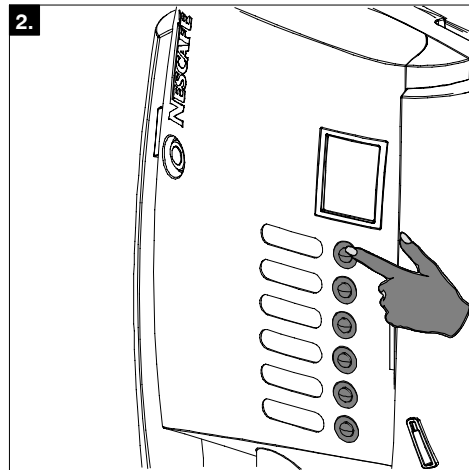
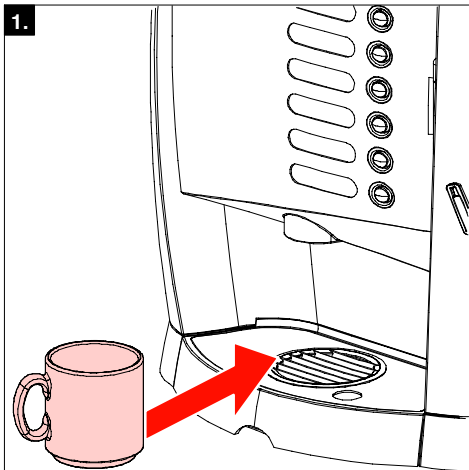

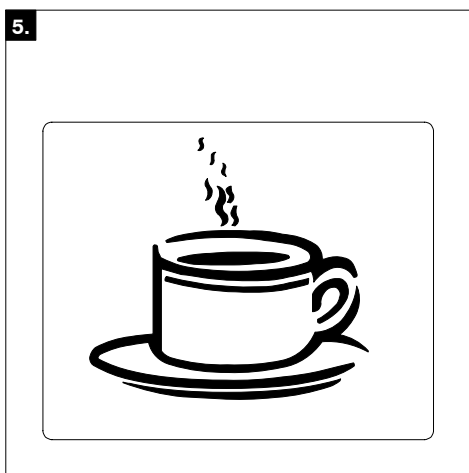
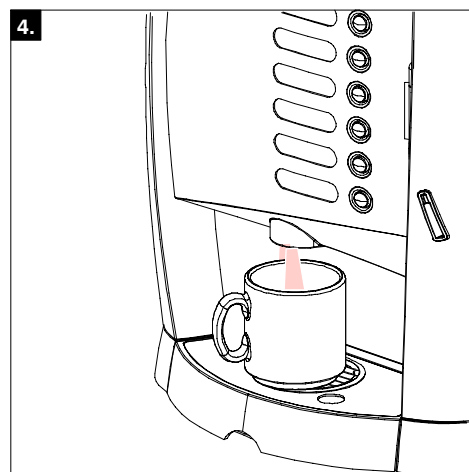
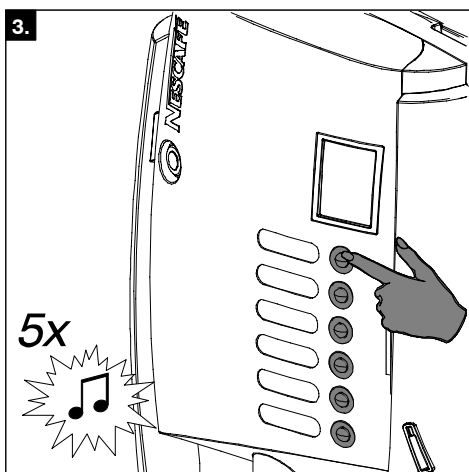
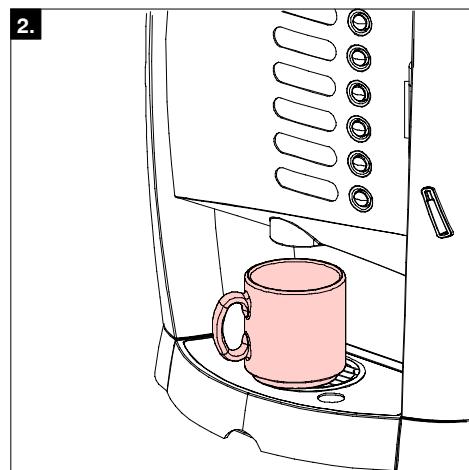
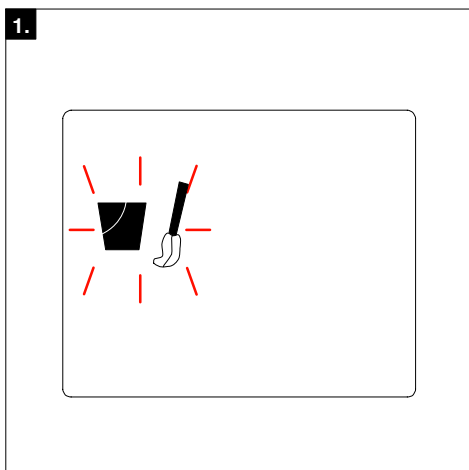
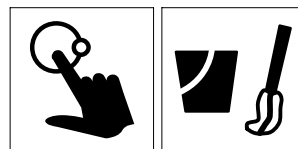

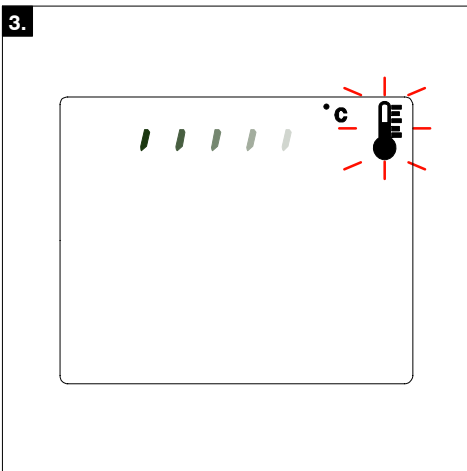
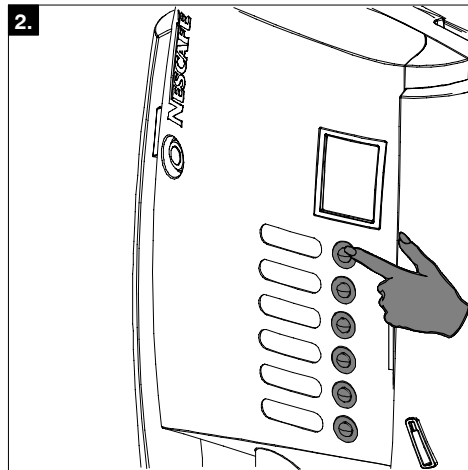
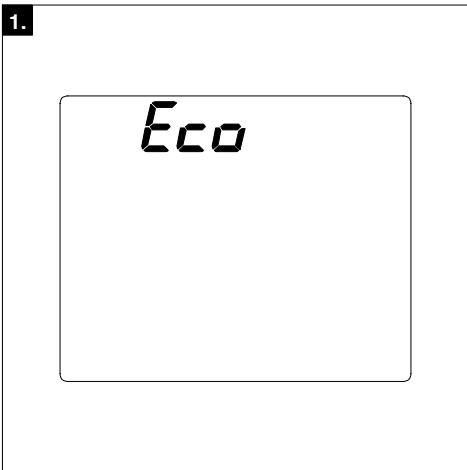
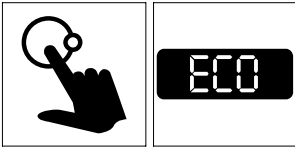

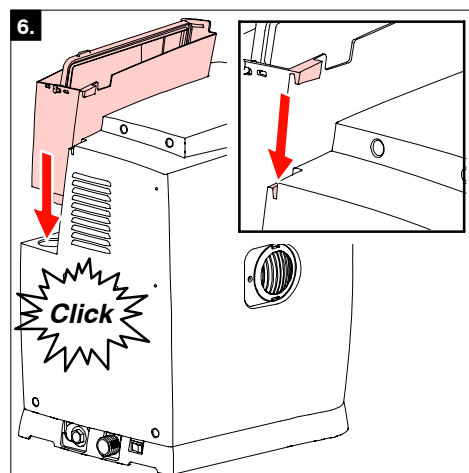
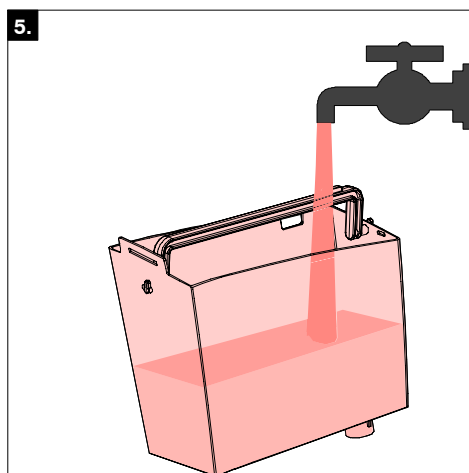
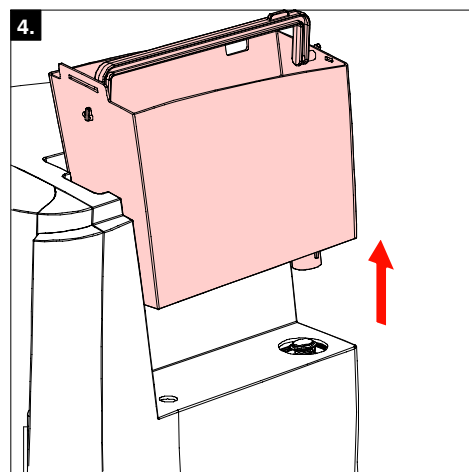
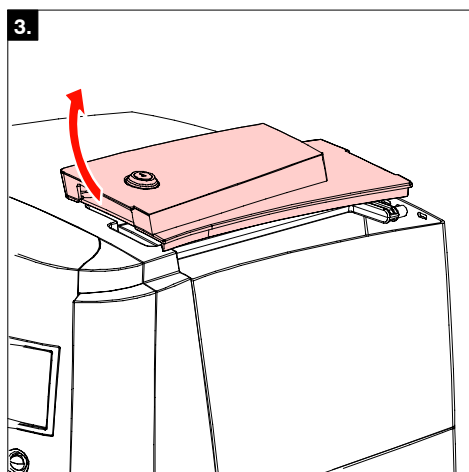
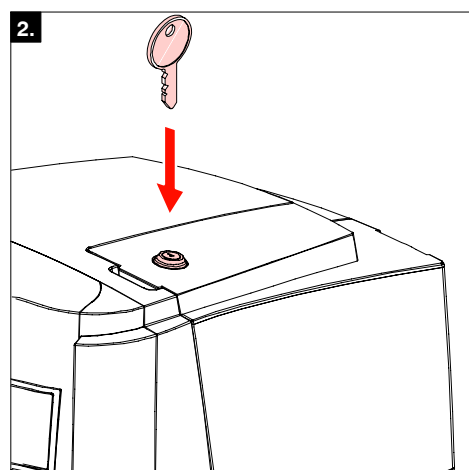
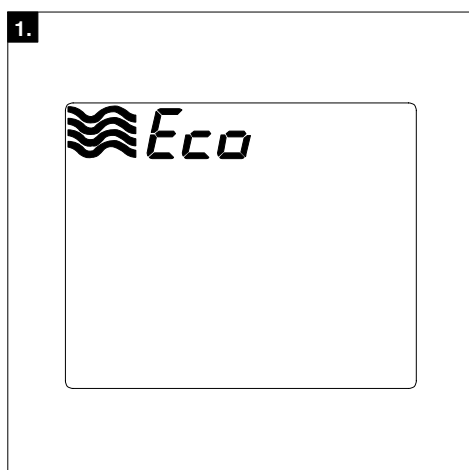
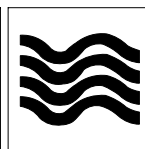

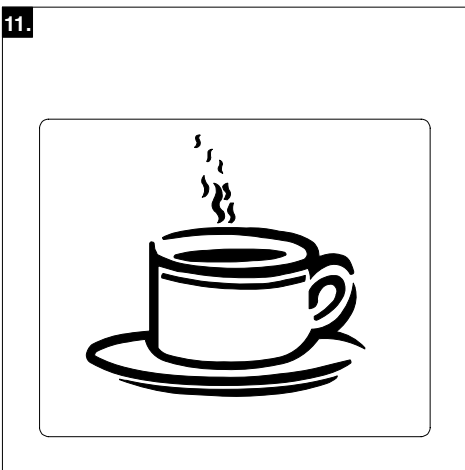
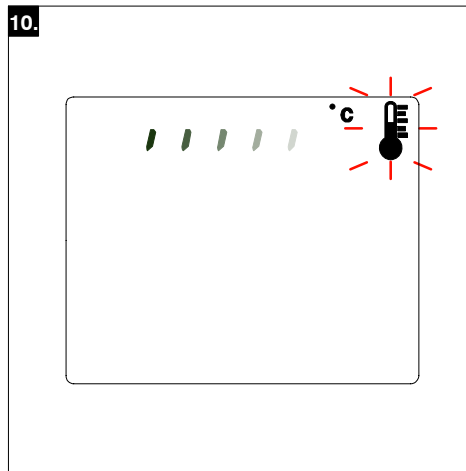
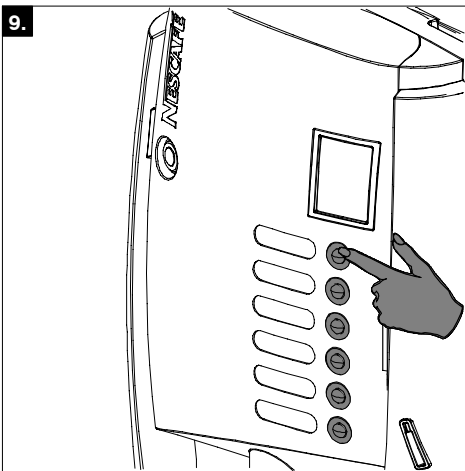
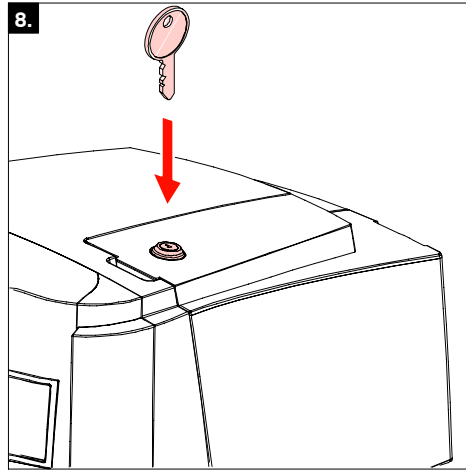
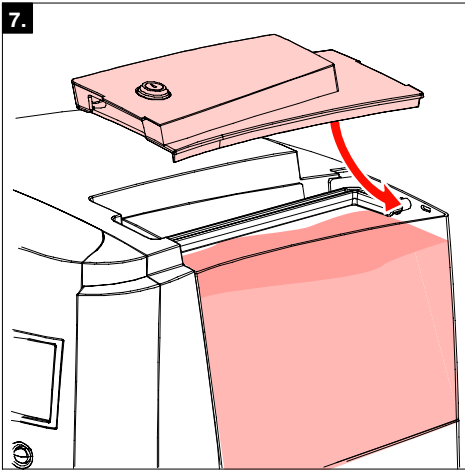
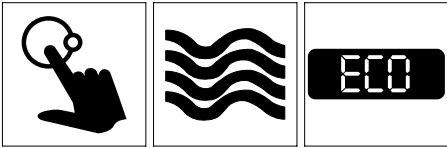



Fill / empty
Remplissage /
vidange
Füllen / Entleeren
Vullen / legen
Påfyllning /
tömning

Fyll / Tøm
Fuld / Tom
Täyttö / tyhjennys
lenar / vaciar
Cheio / vazio

Riempire /
scaricare
Ενδειξη γεμάτο /
Άδειο
Plný / prázdny
Peľny / pusty
Plin / Gol

Наполнить /
опорожнить
Doldurma /
Boşaltma
滿/空
給水・空にする
채움/텅빈

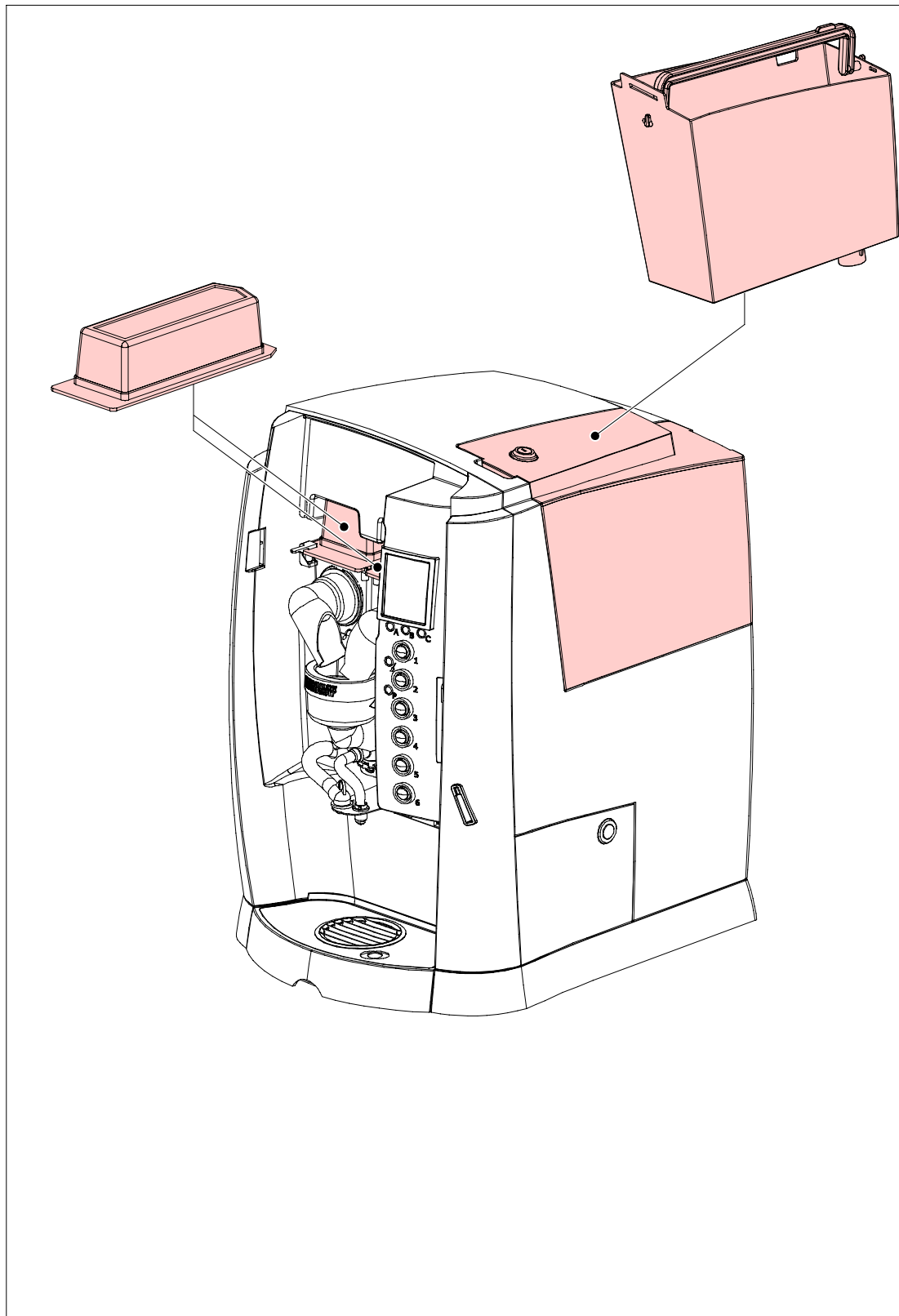

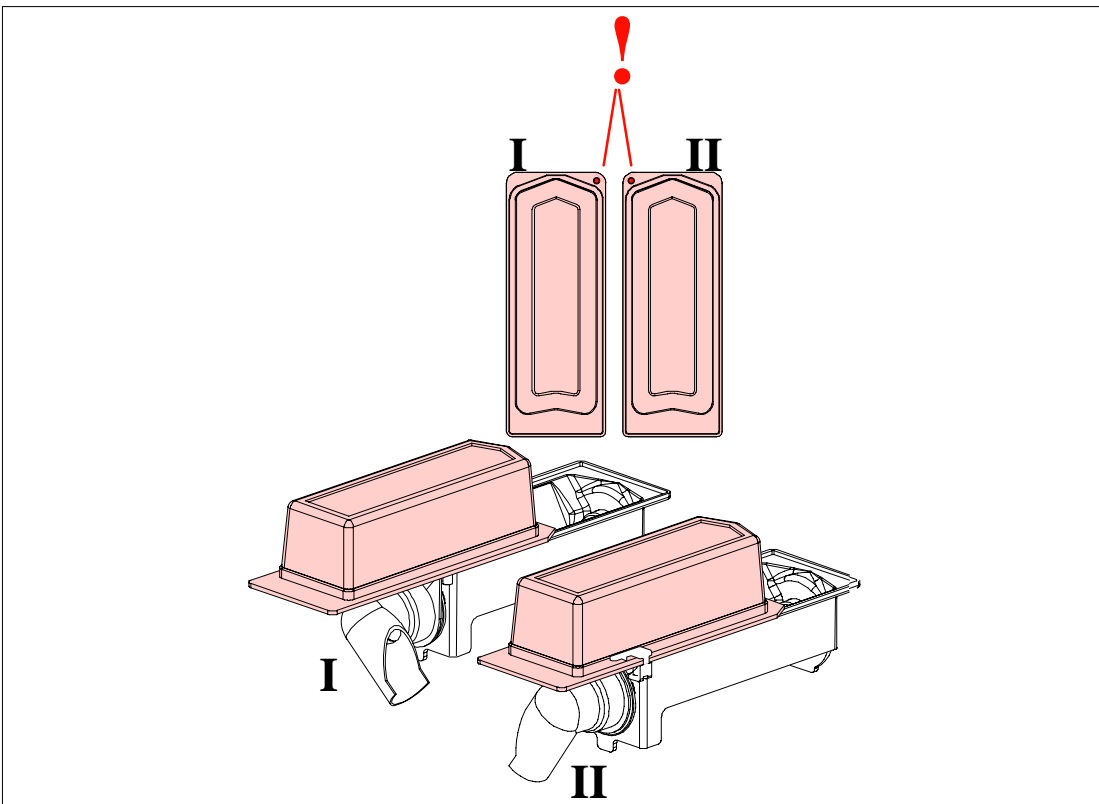
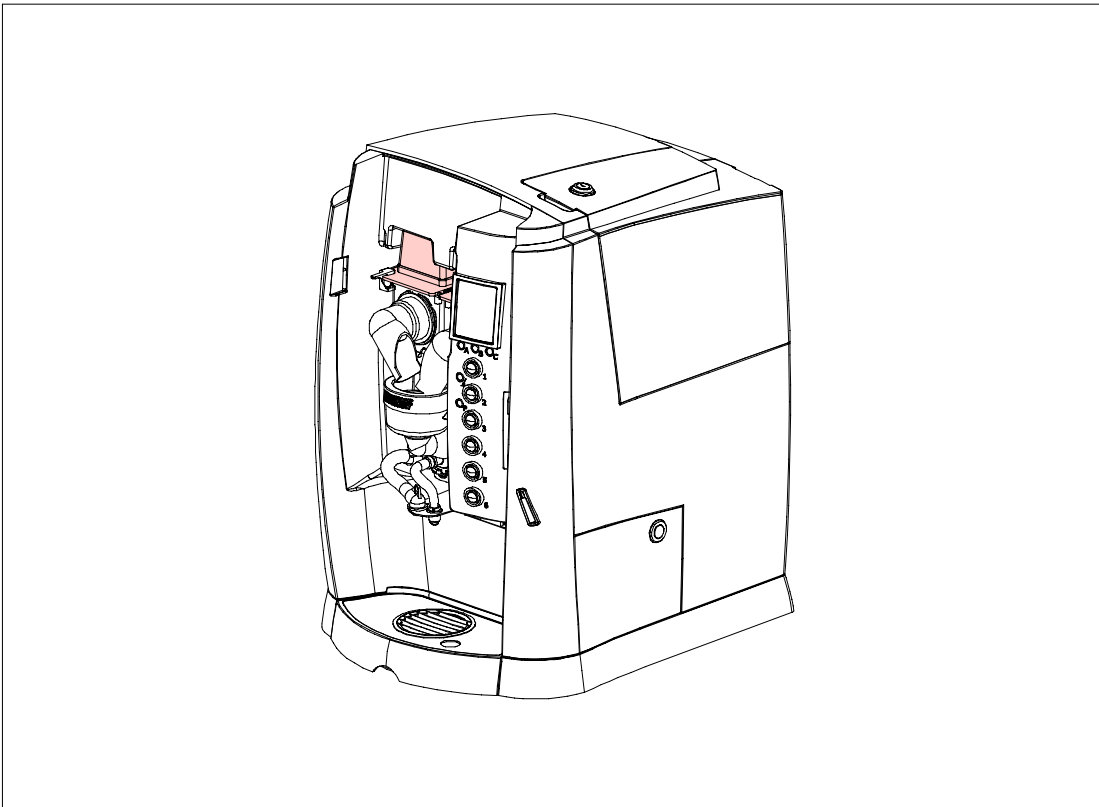
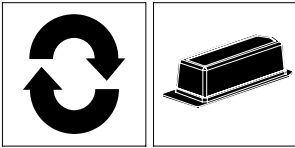

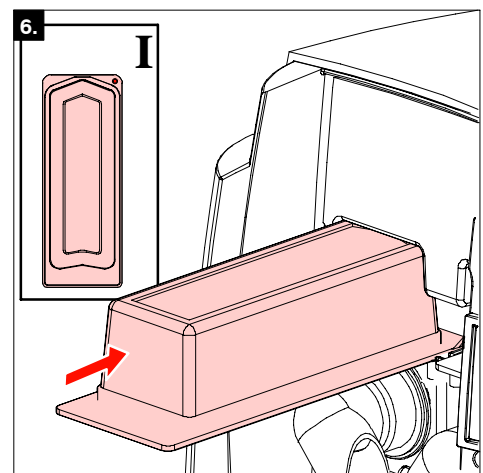
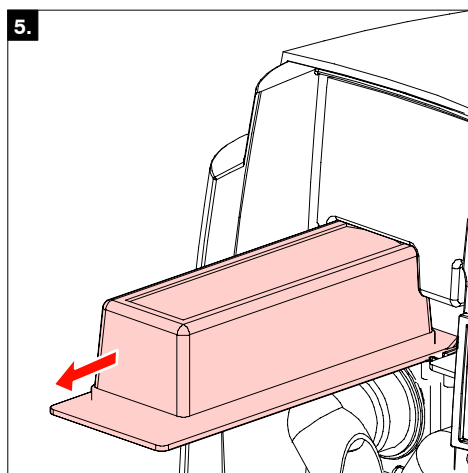
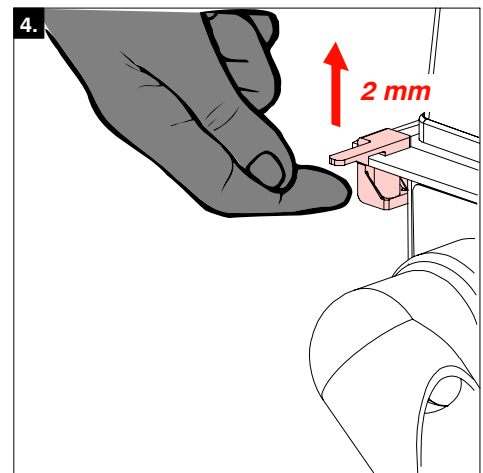
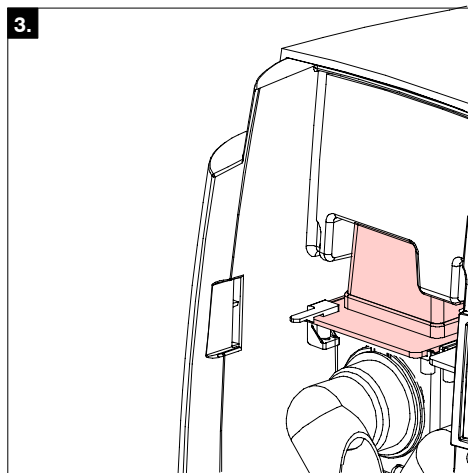
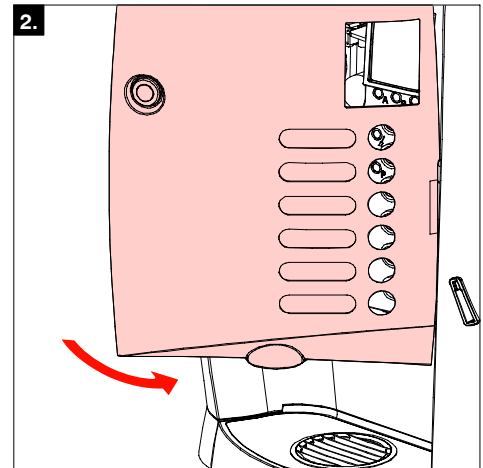
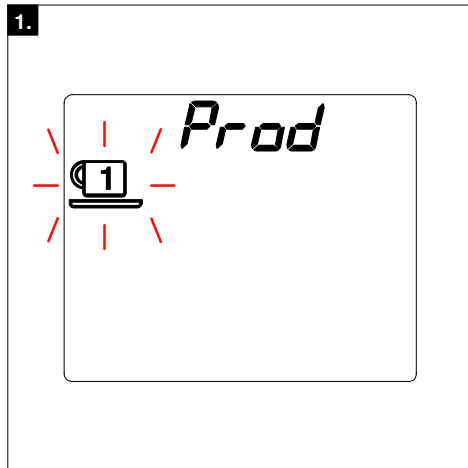
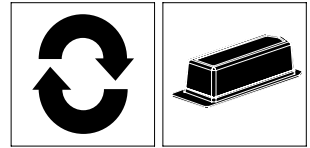

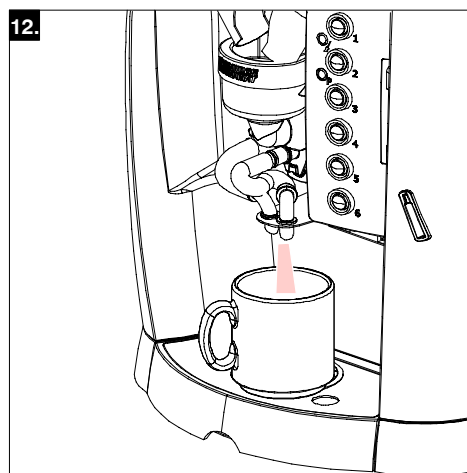
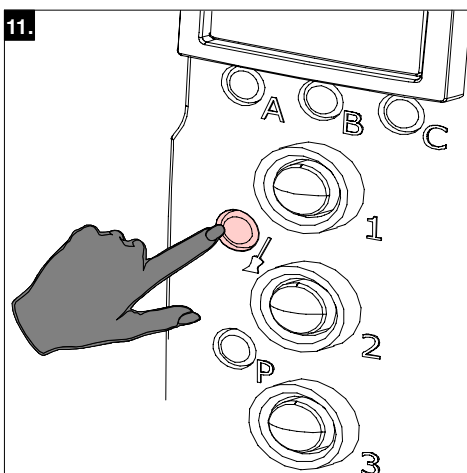
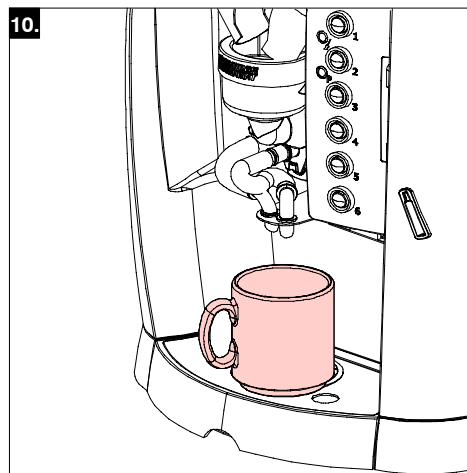
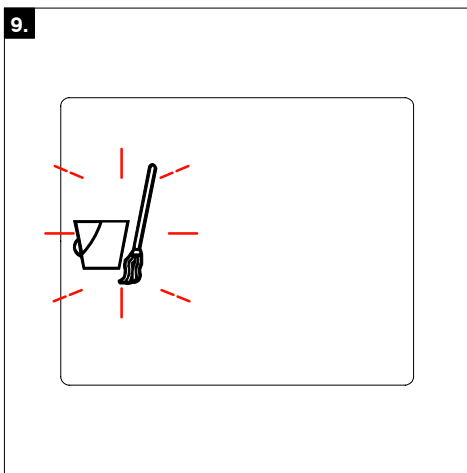
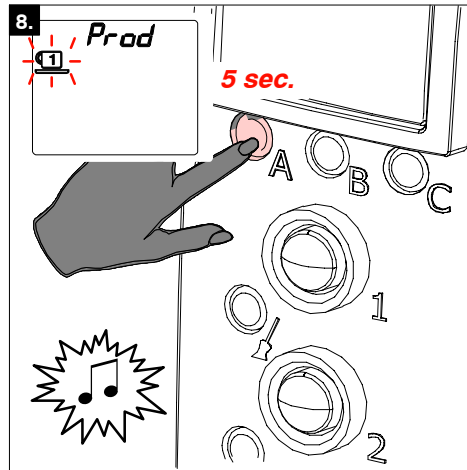
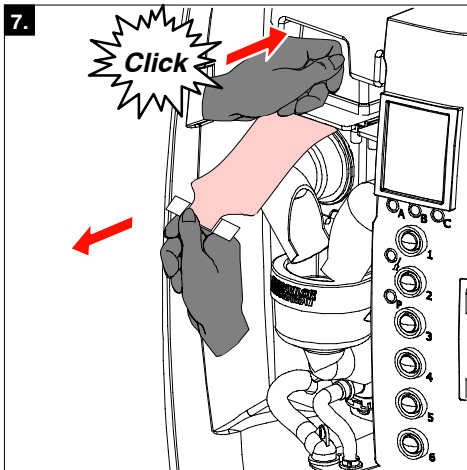
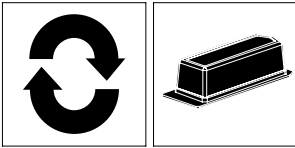

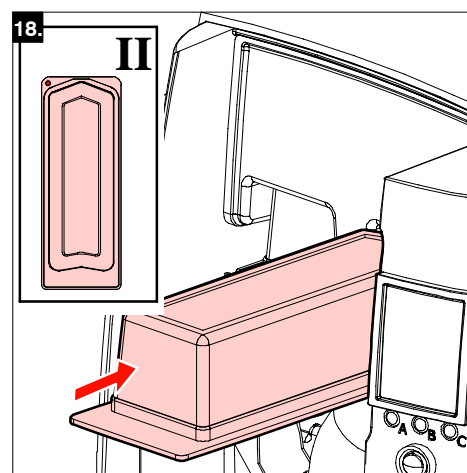
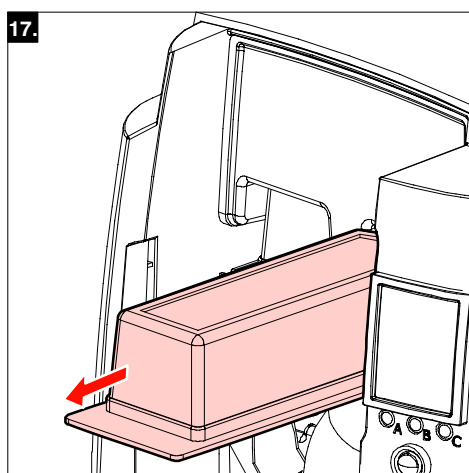
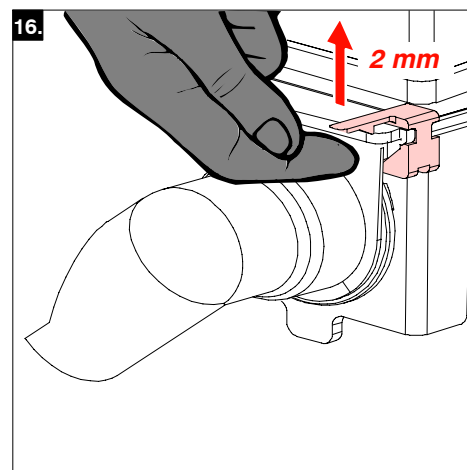
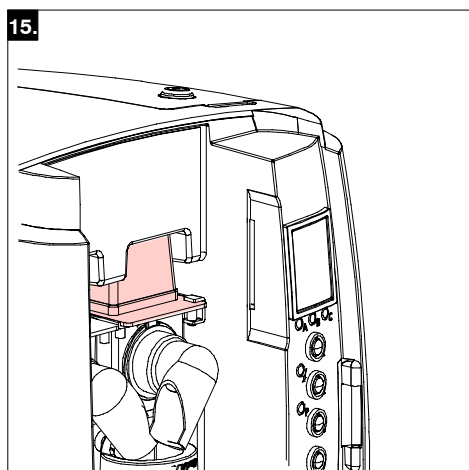
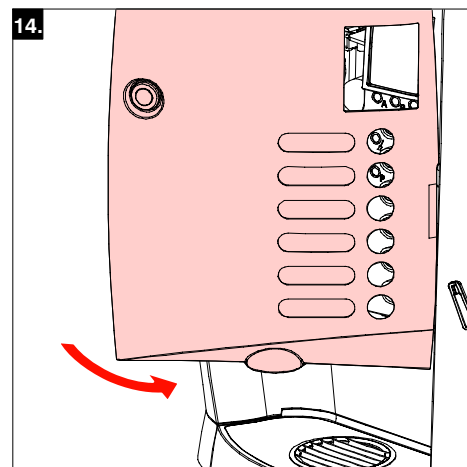
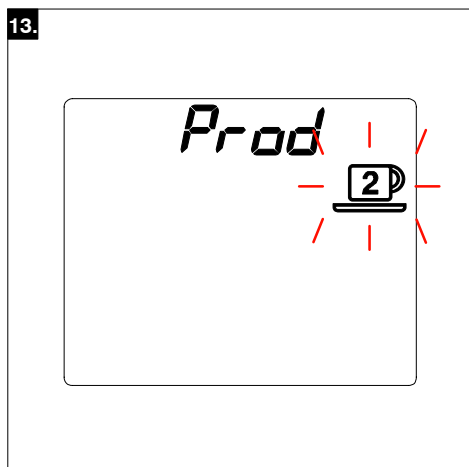
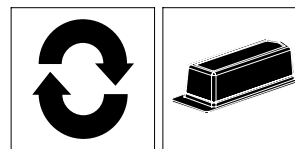

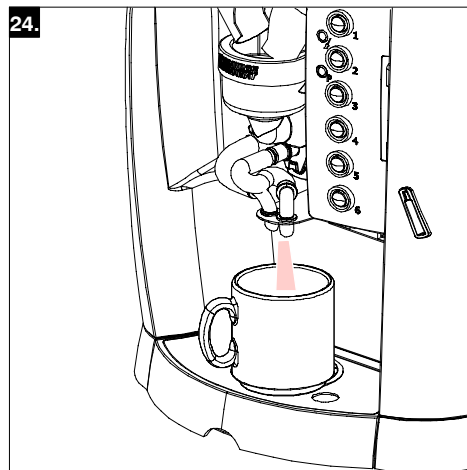
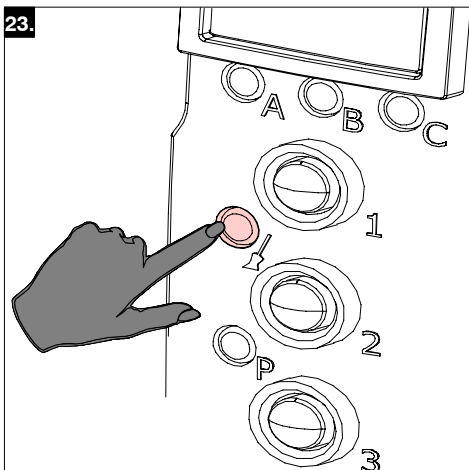
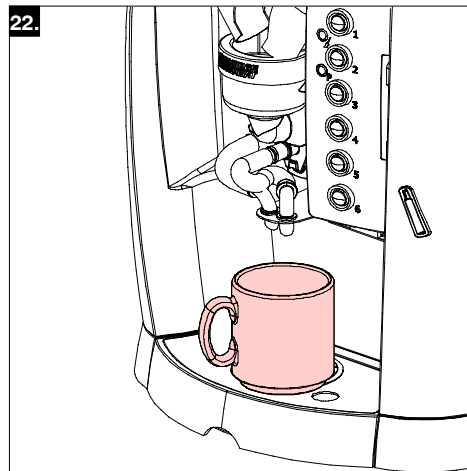
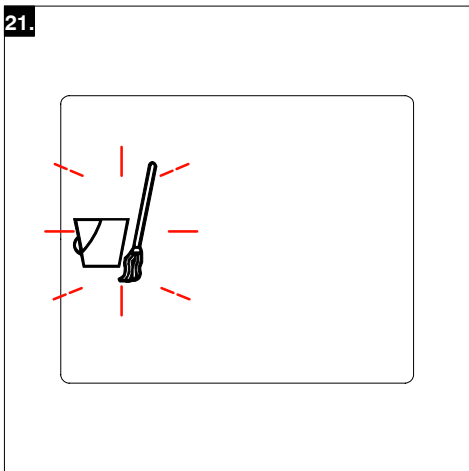
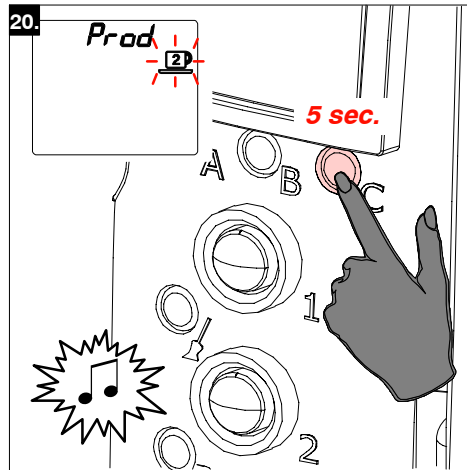
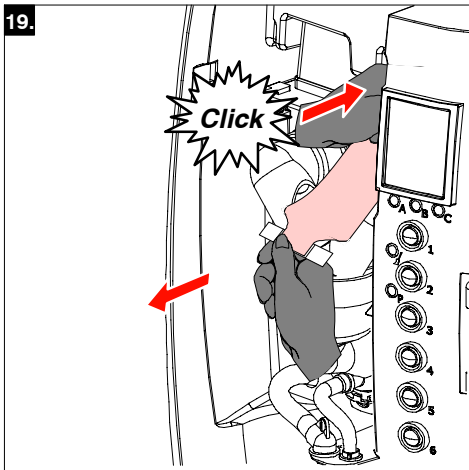
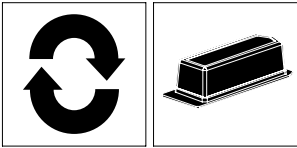

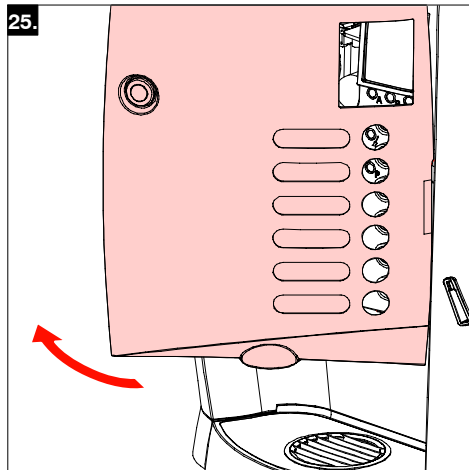
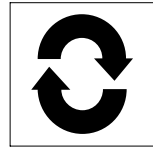

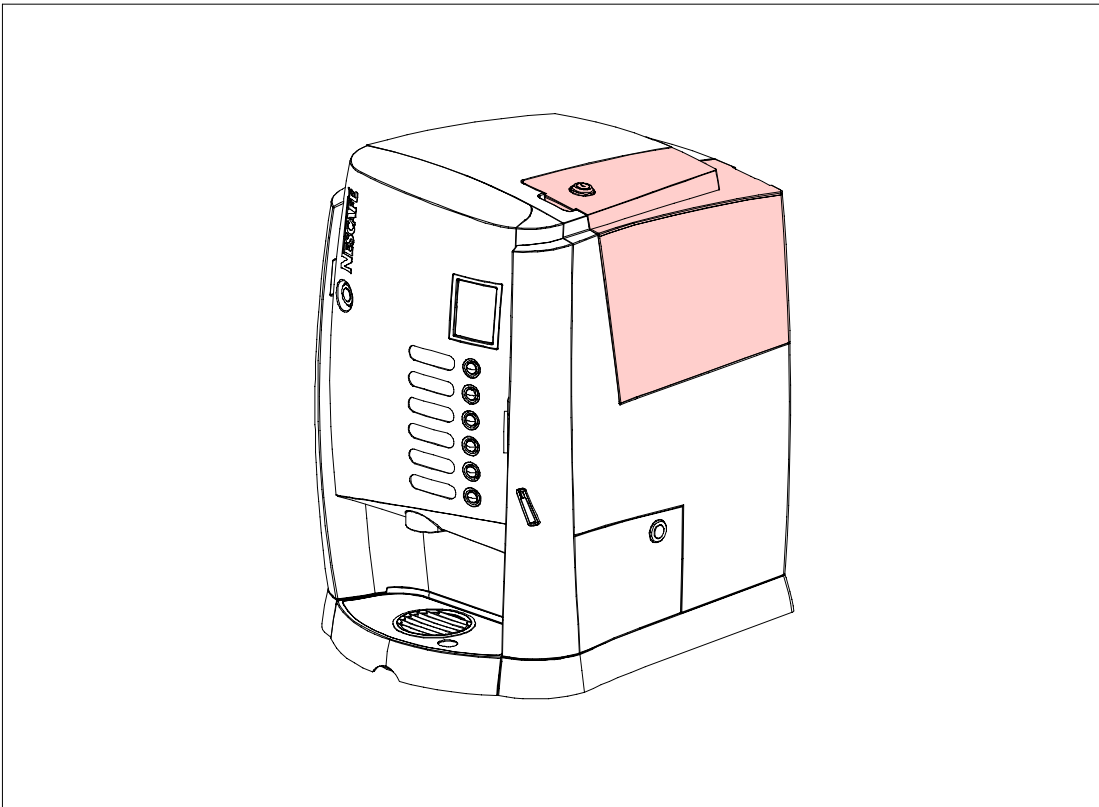
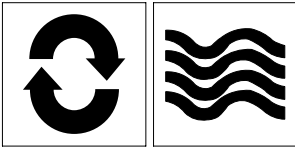

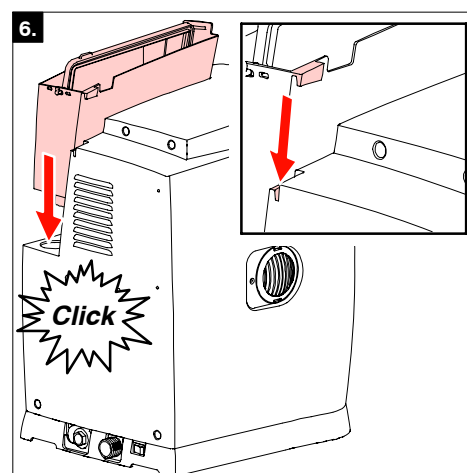
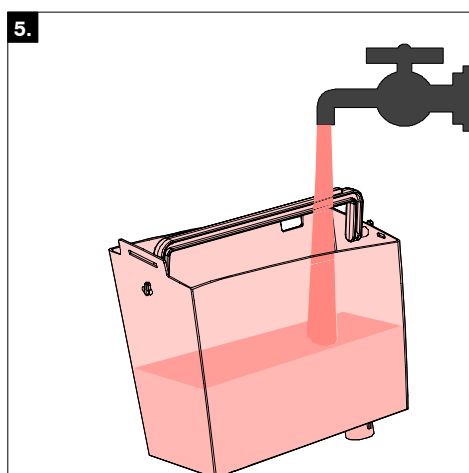
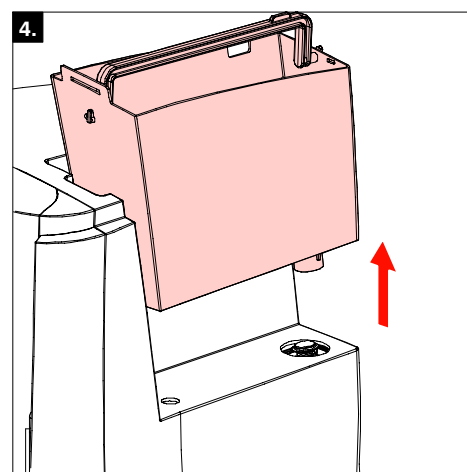
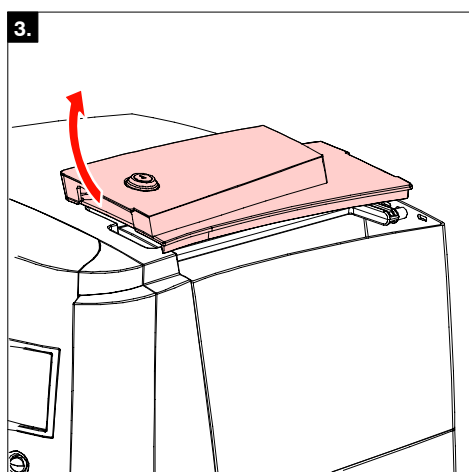
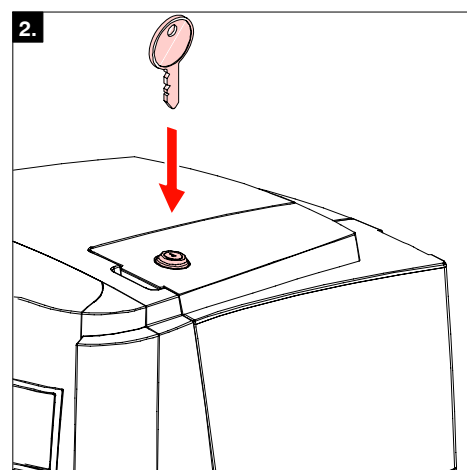
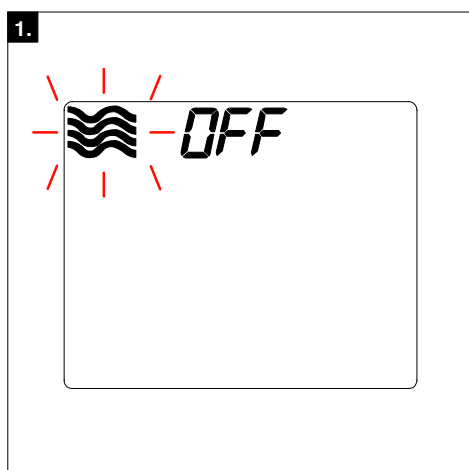
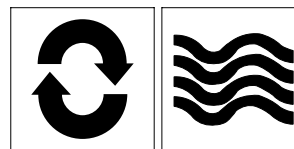

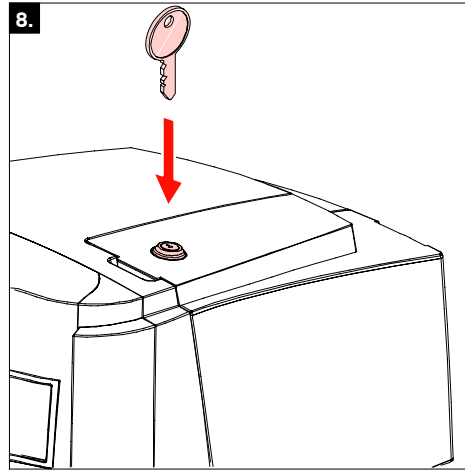
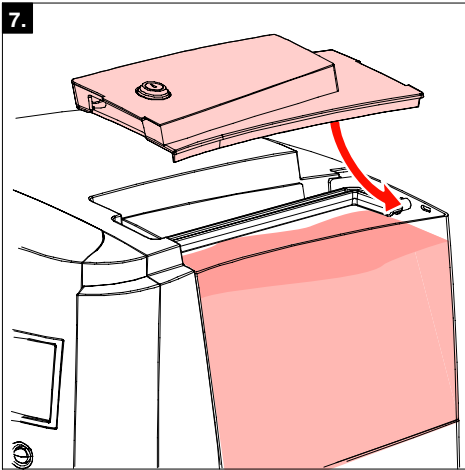
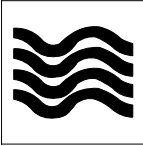

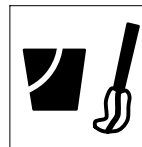

Cleaning
Nettoyage
Reinigung
Schoonmaken
Rengöring

Vasking
Rengøring
Puhdistus
Limpiar
Limpeza

Pulizia
Καθαρισμός
Čištění
Czyszczenie
Curațare

уистка
Temizleme
清洗
洗淨
청소

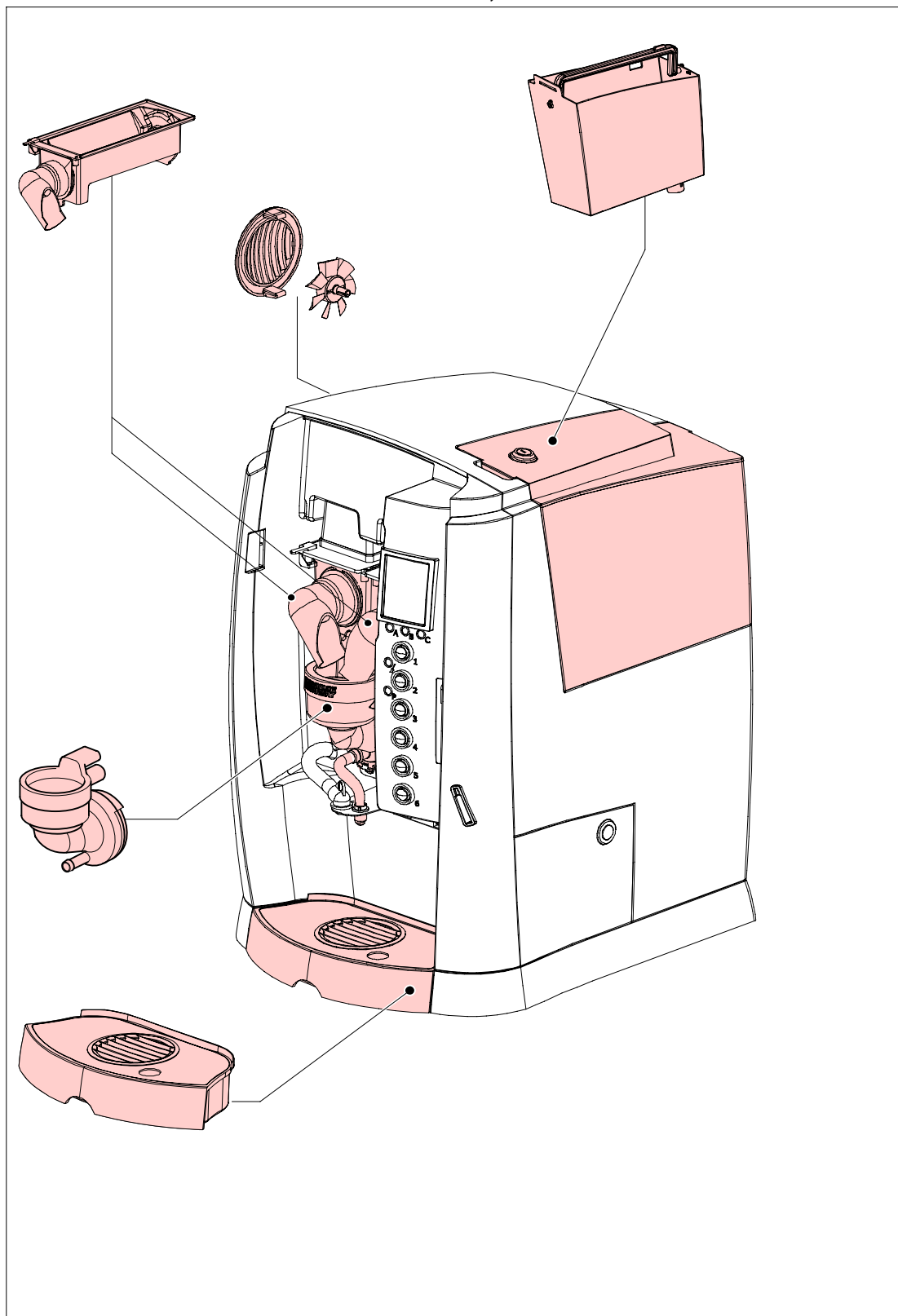

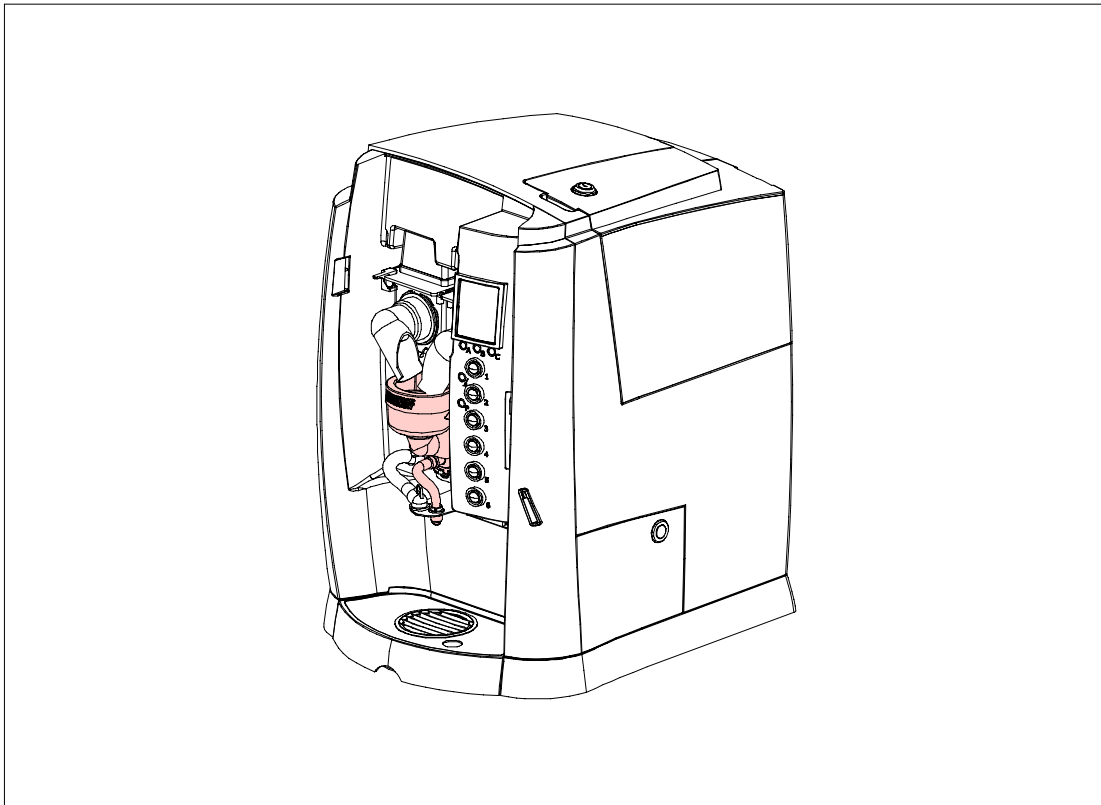
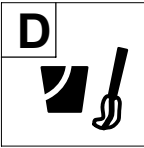

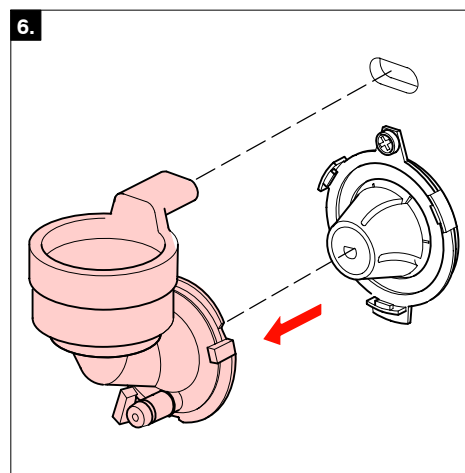
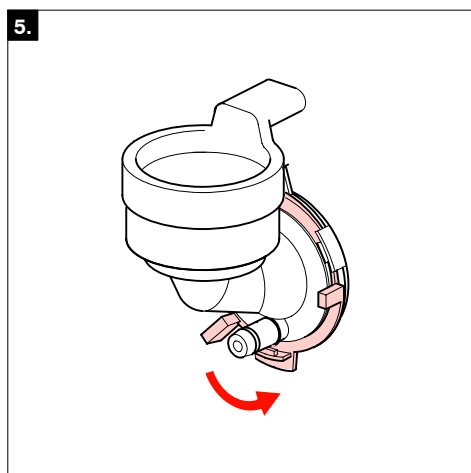
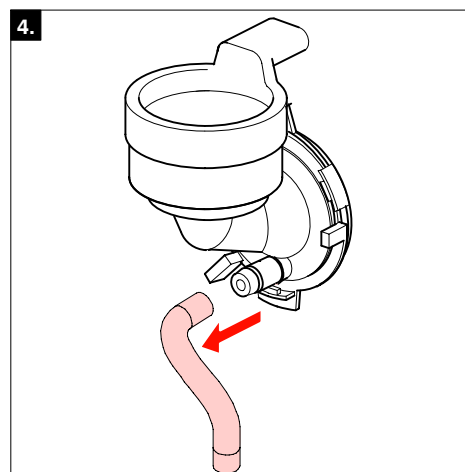
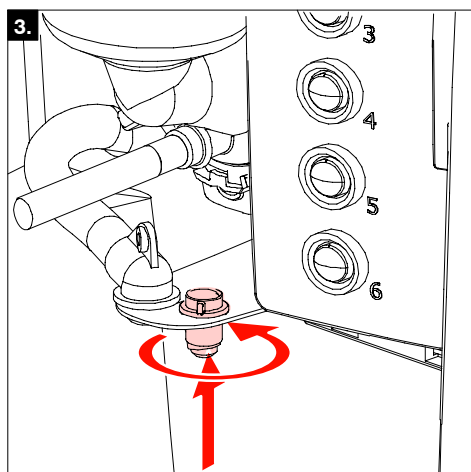
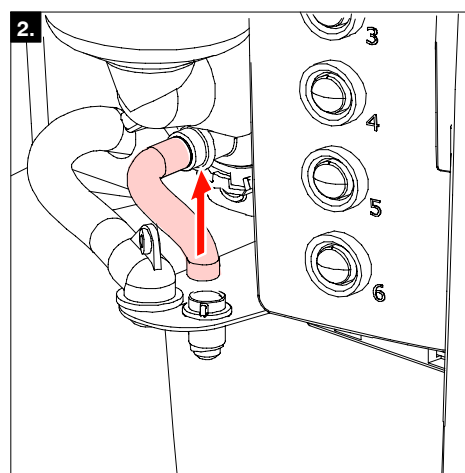
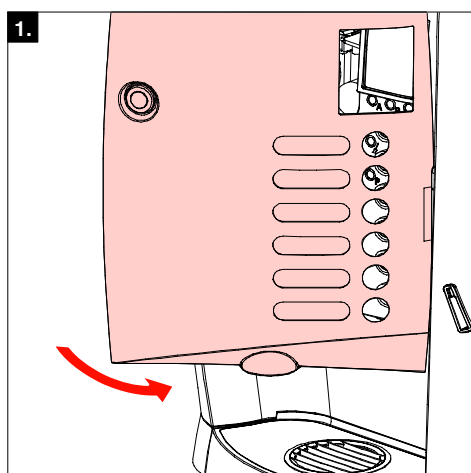
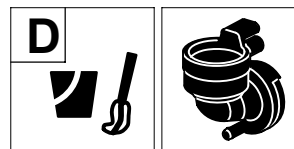

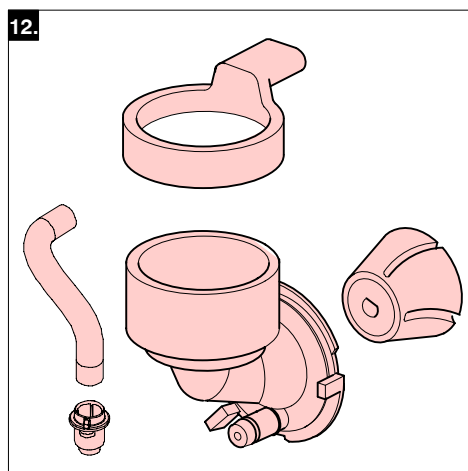
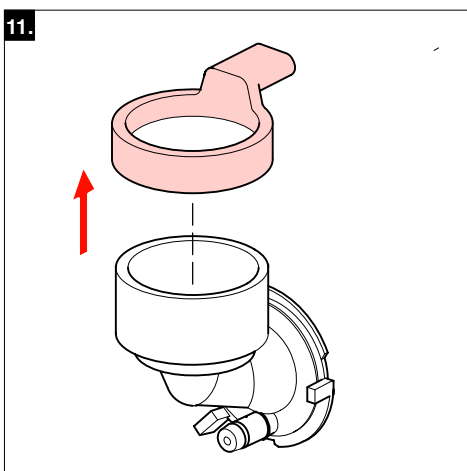
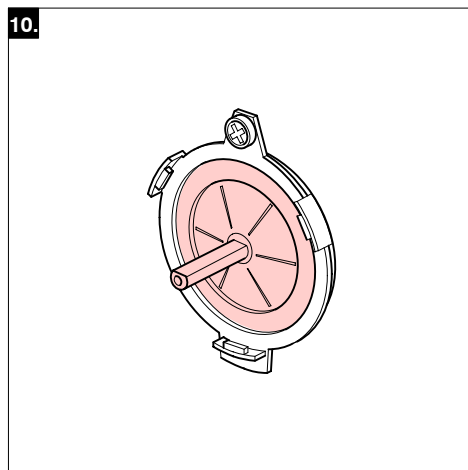
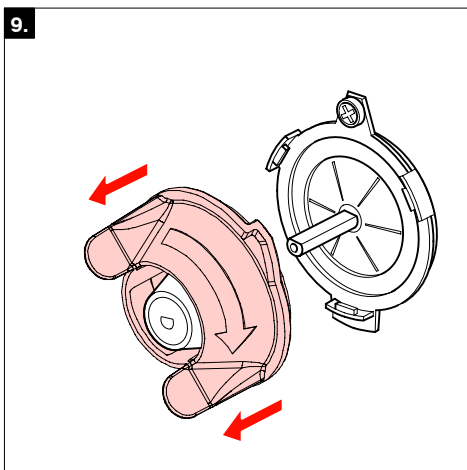
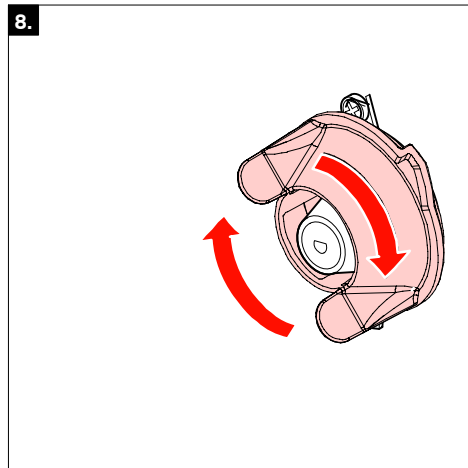
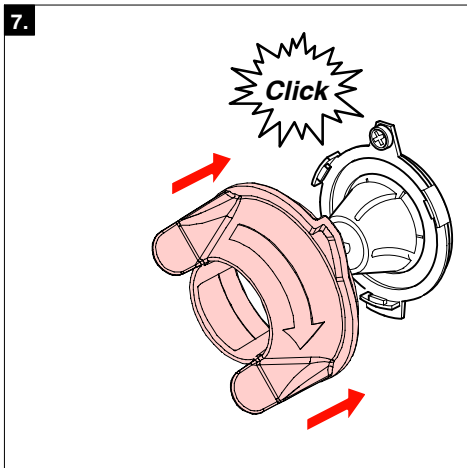
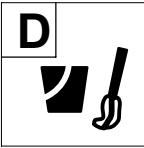

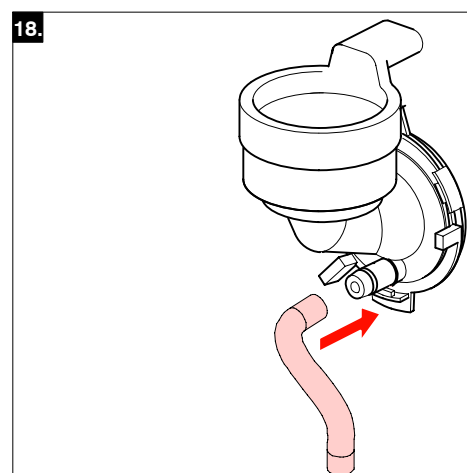
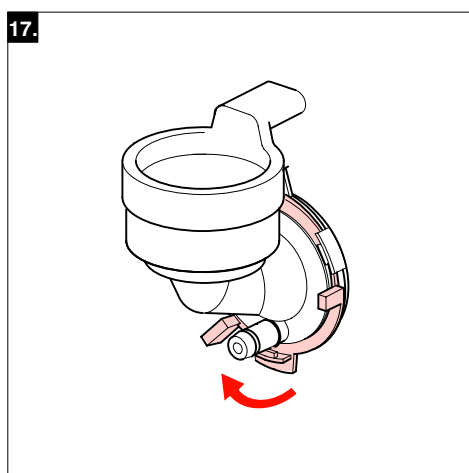
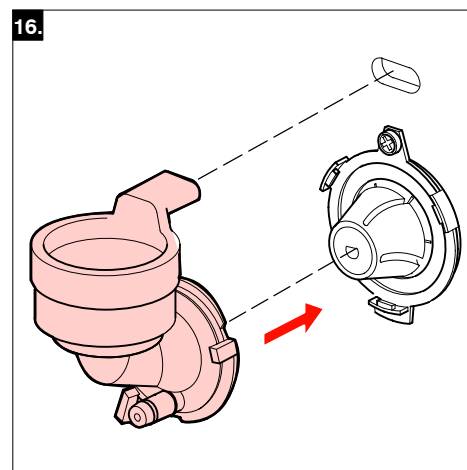
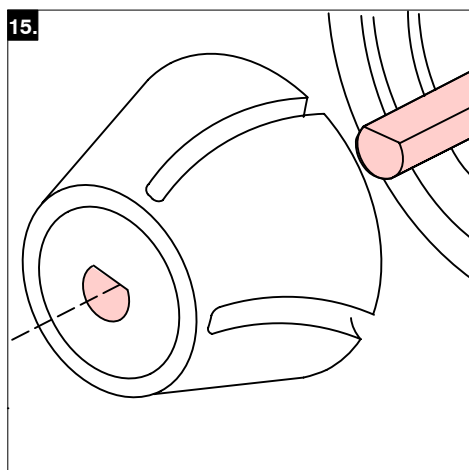
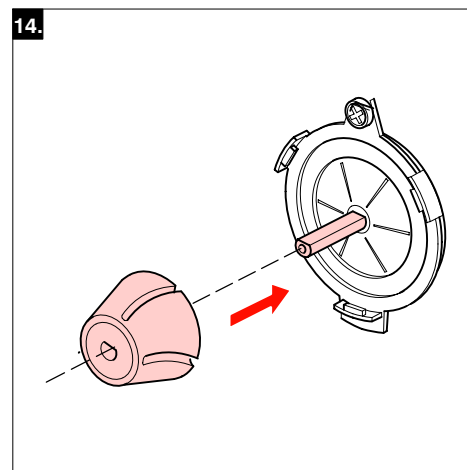
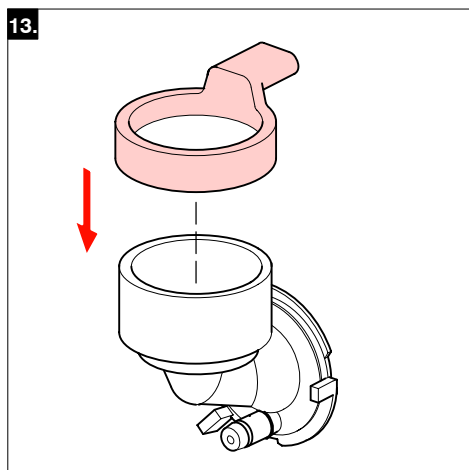
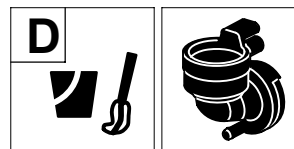

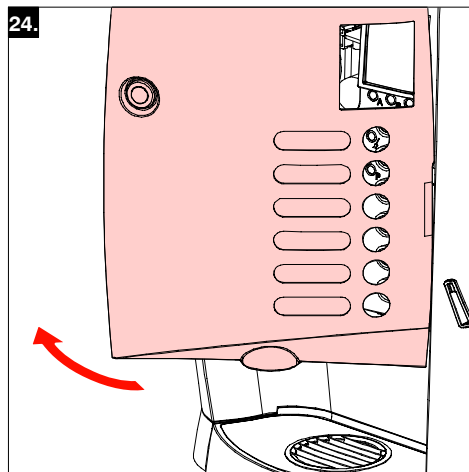
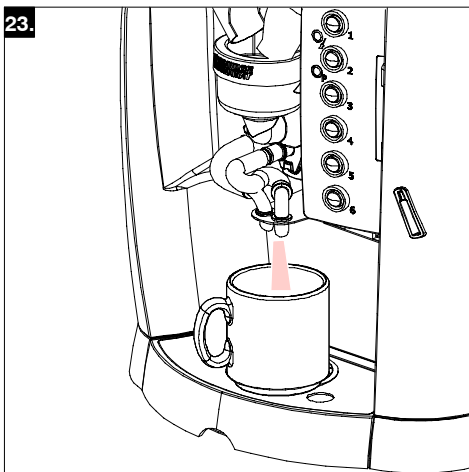
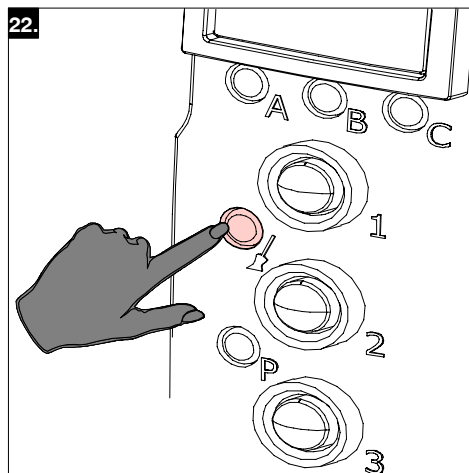
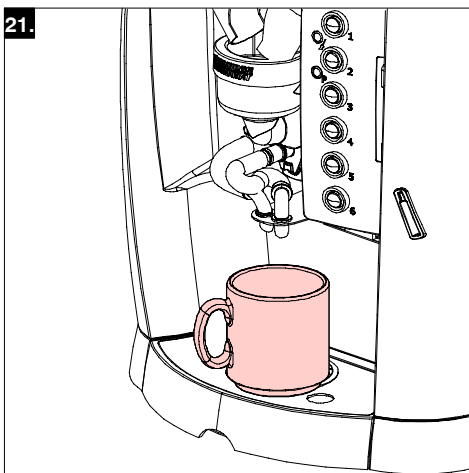
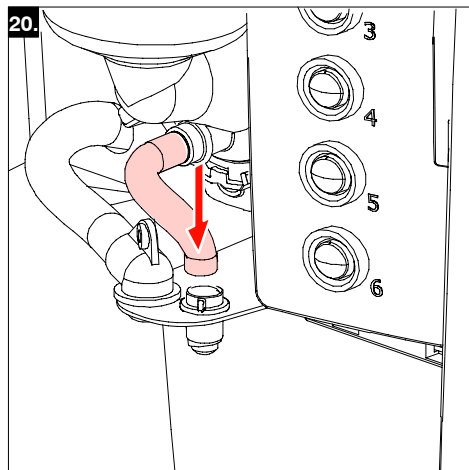
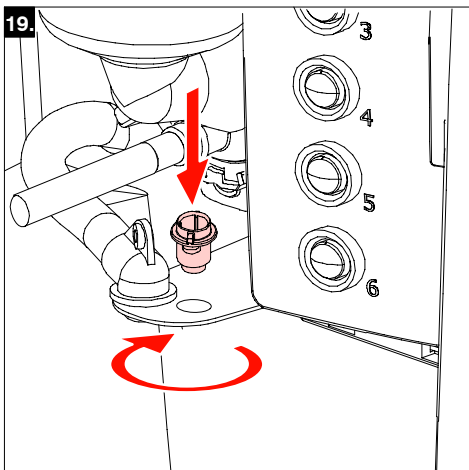
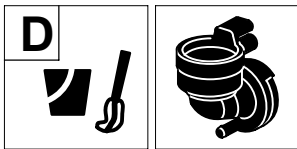

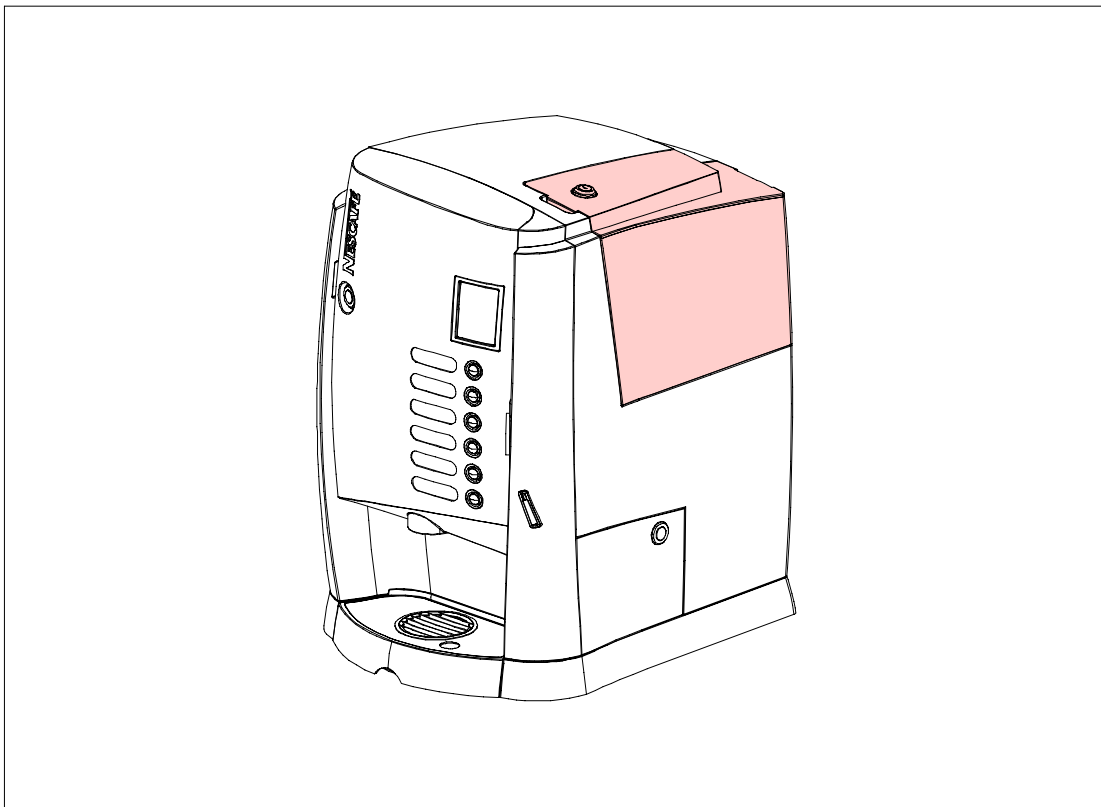
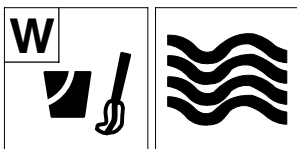

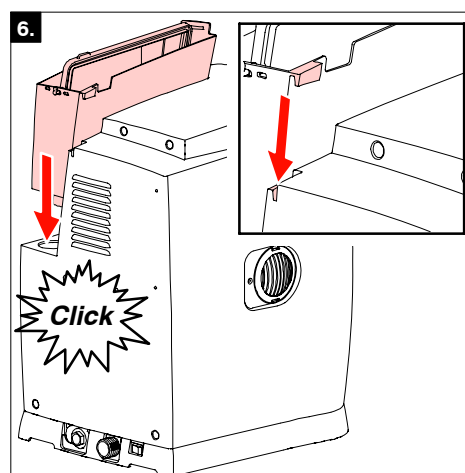
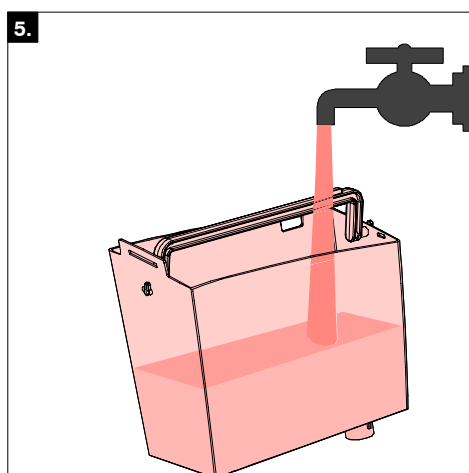
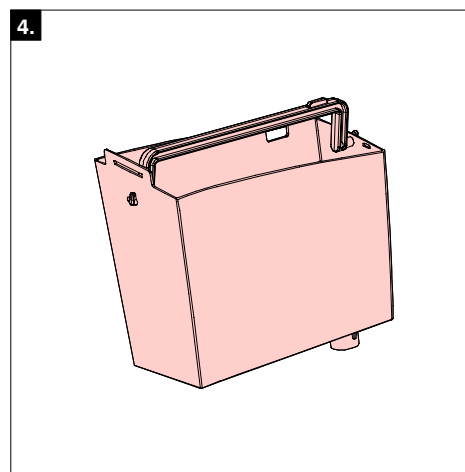
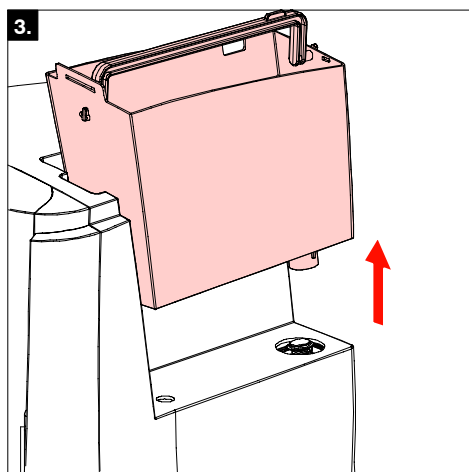
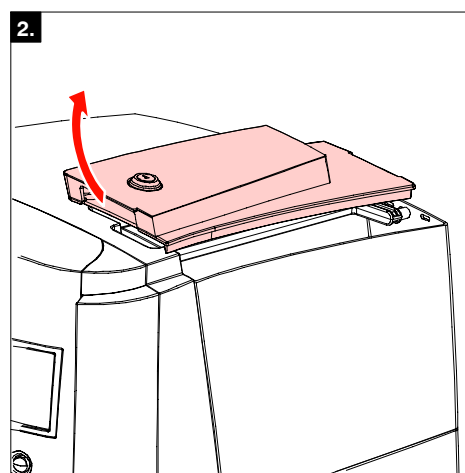
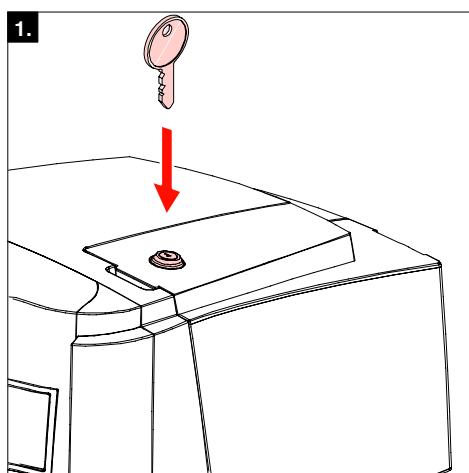
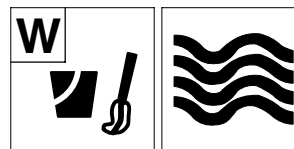

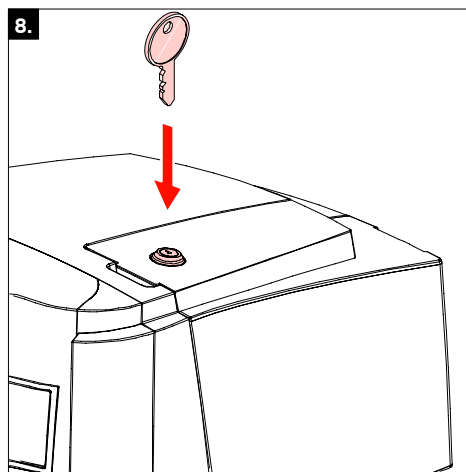
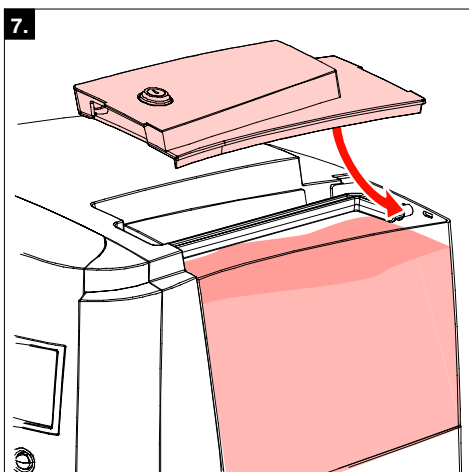
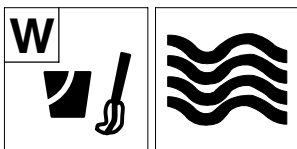

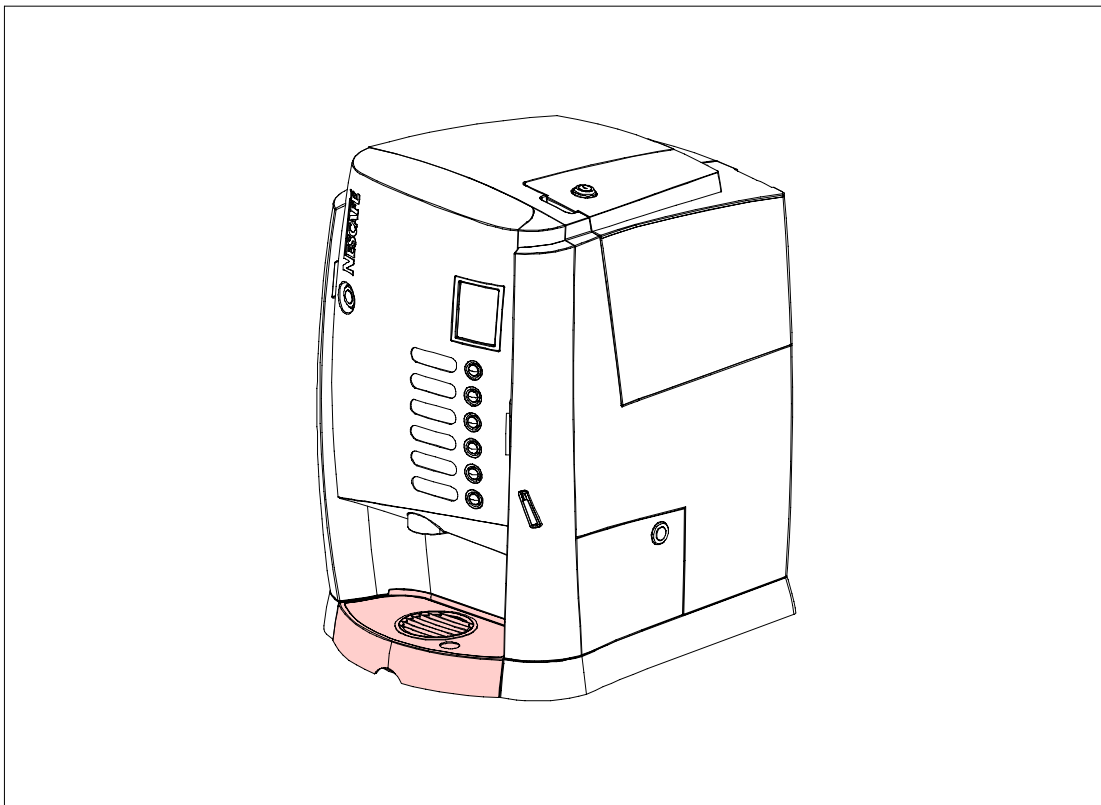
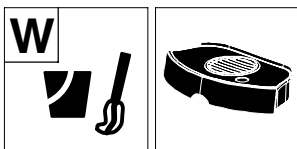

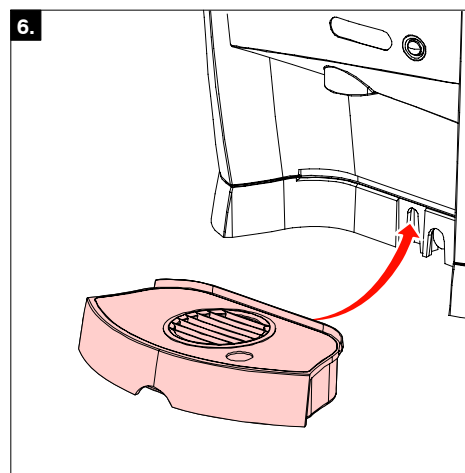
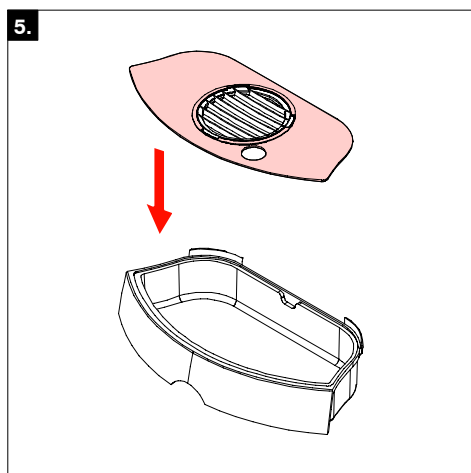
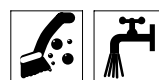
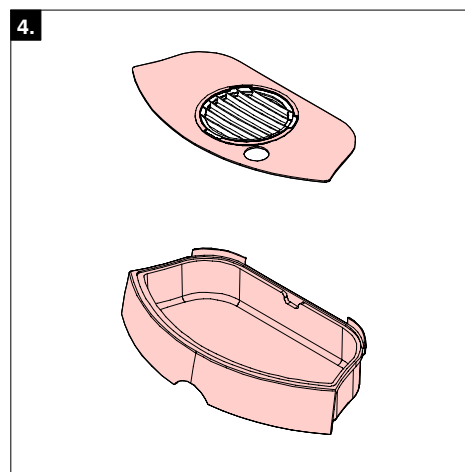
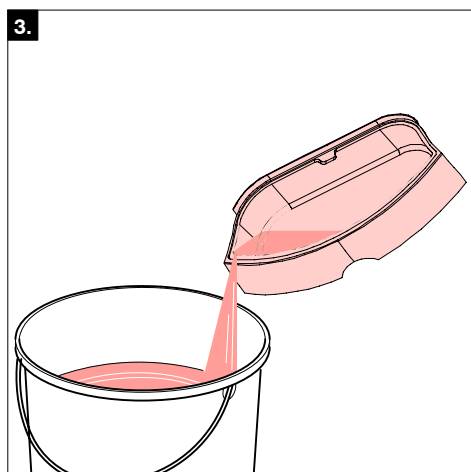
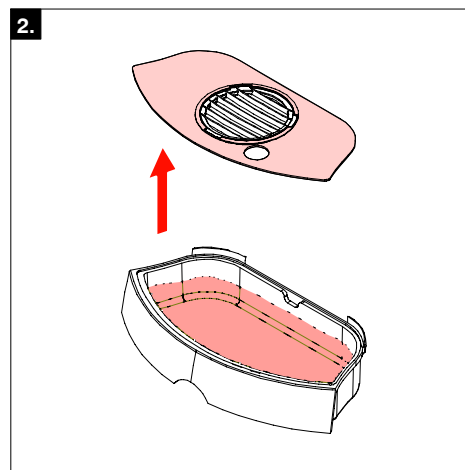
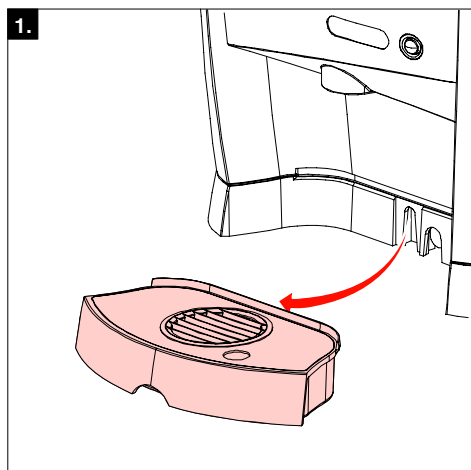
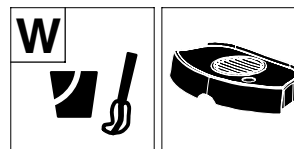

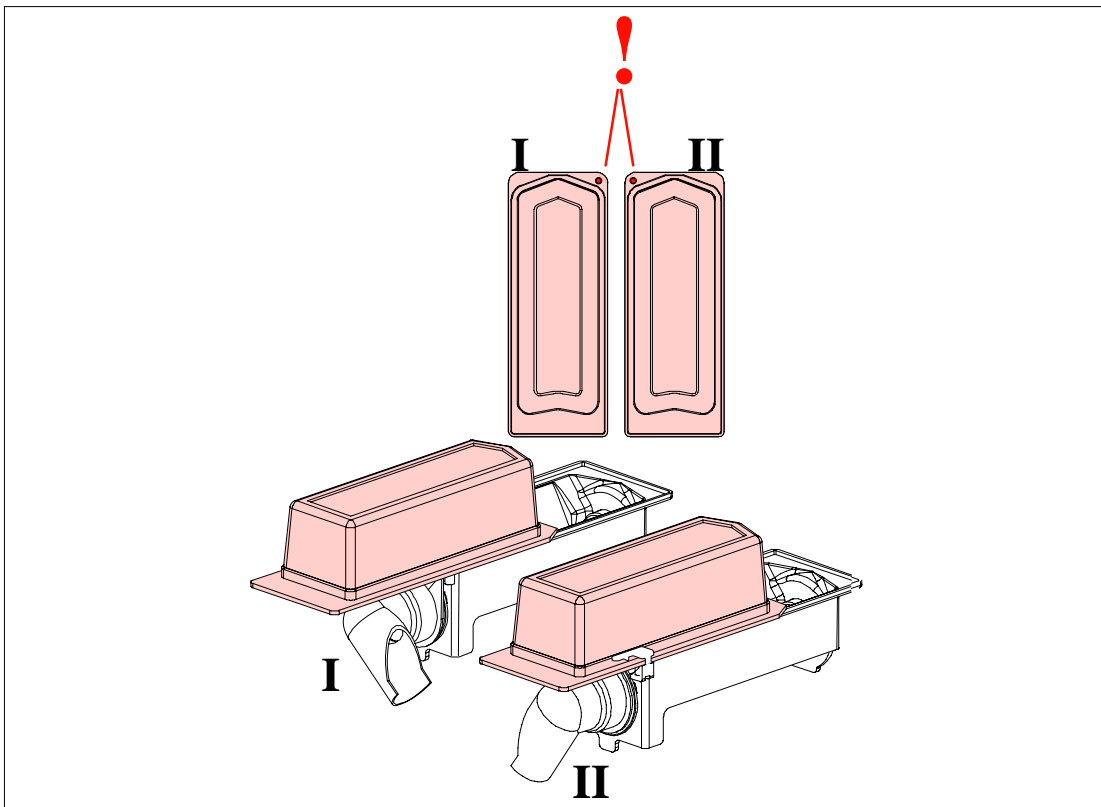
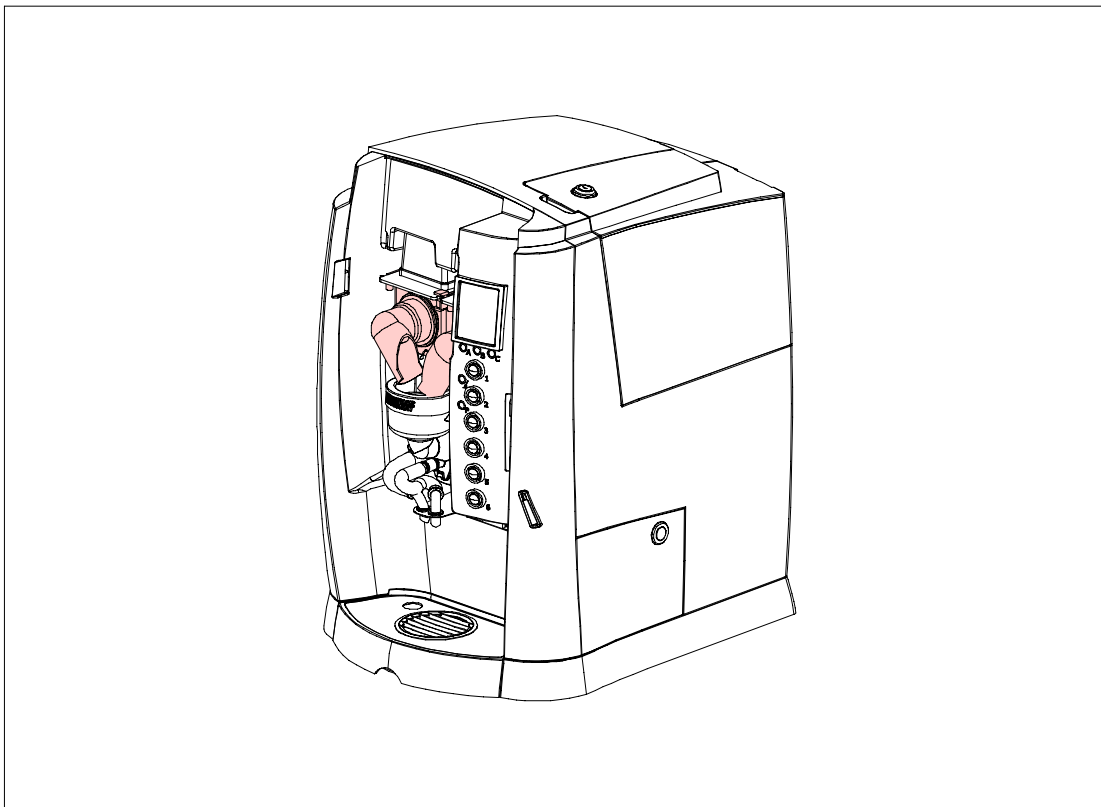
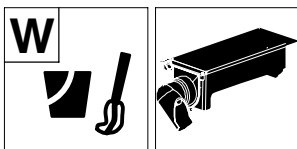

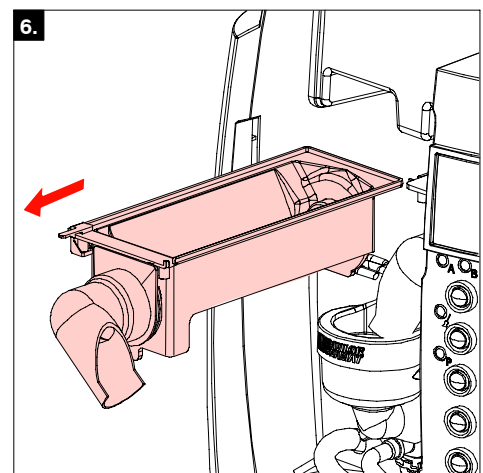
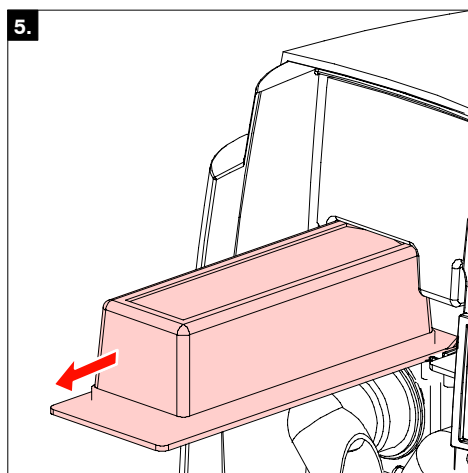
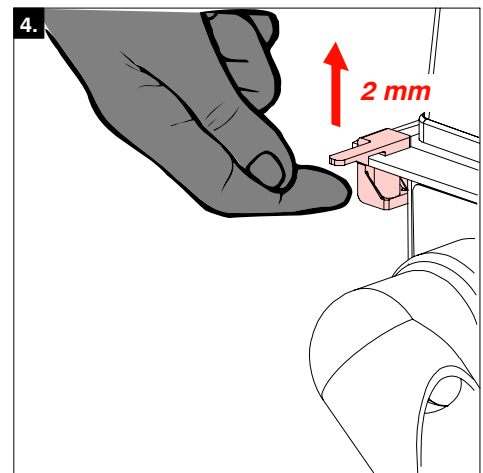
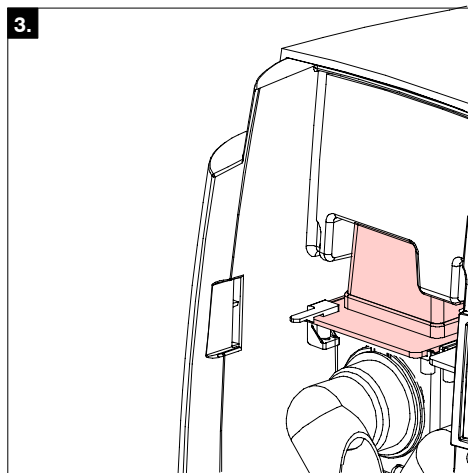
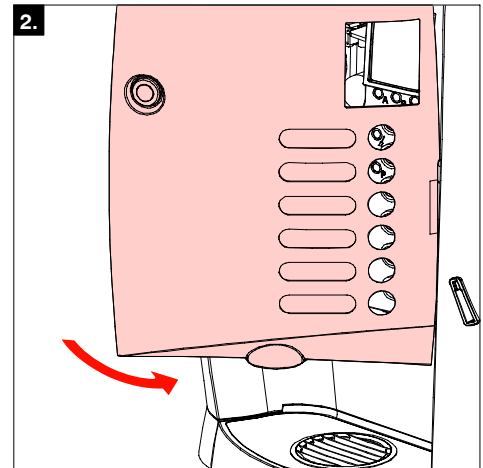
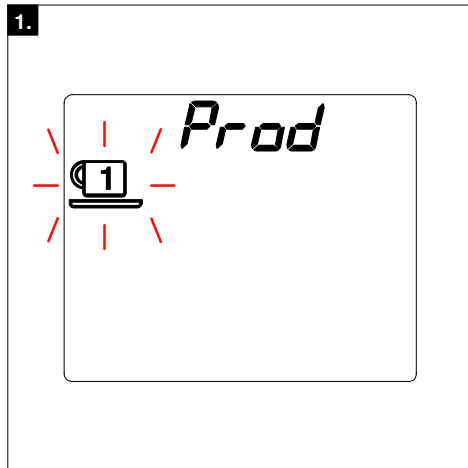
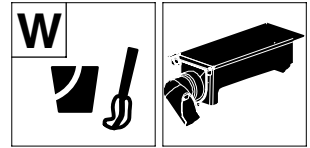

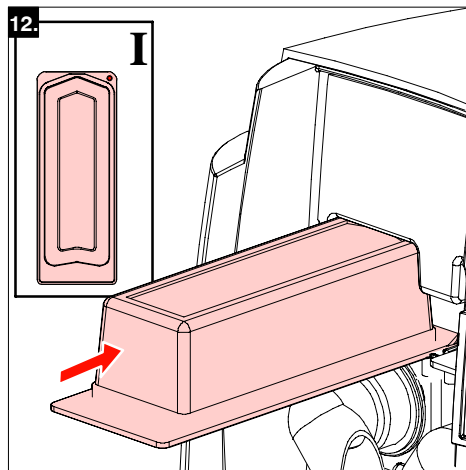
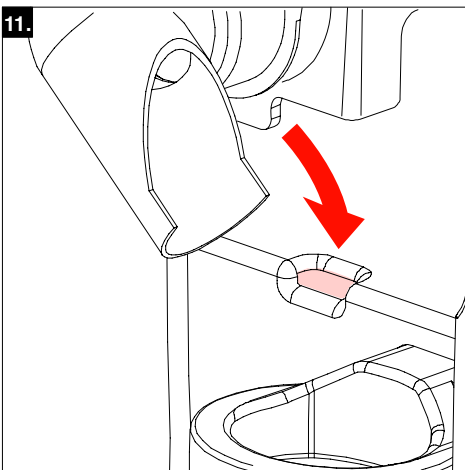
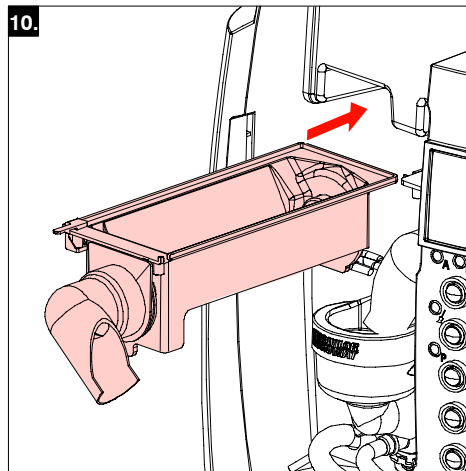
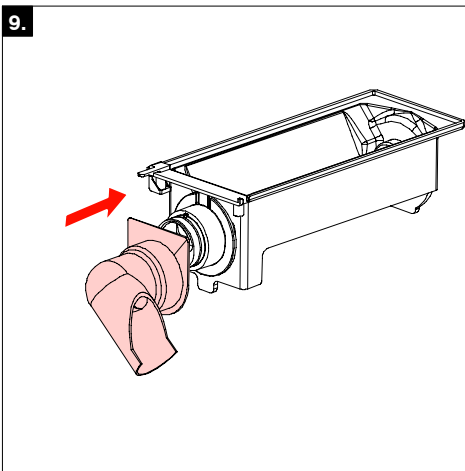
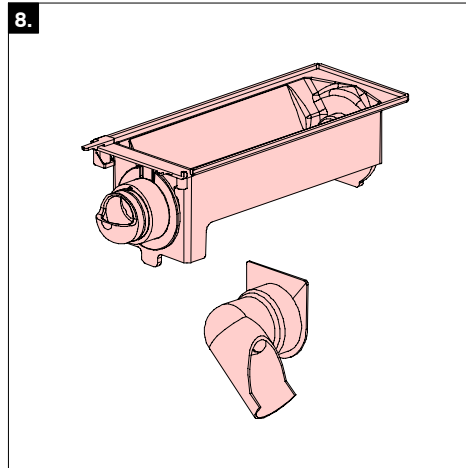
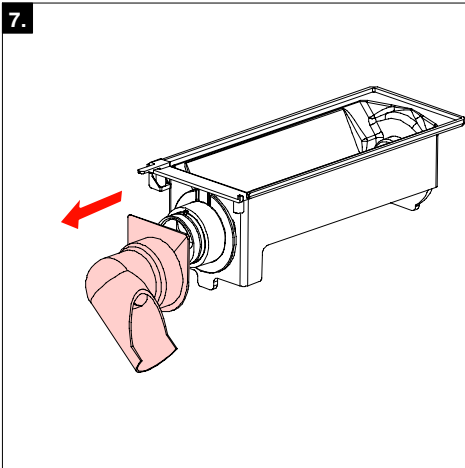
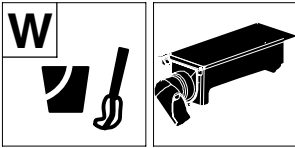

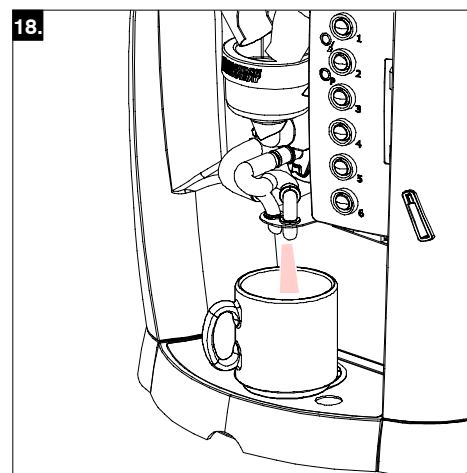
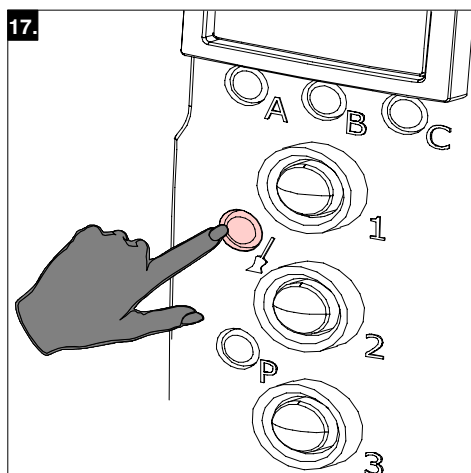
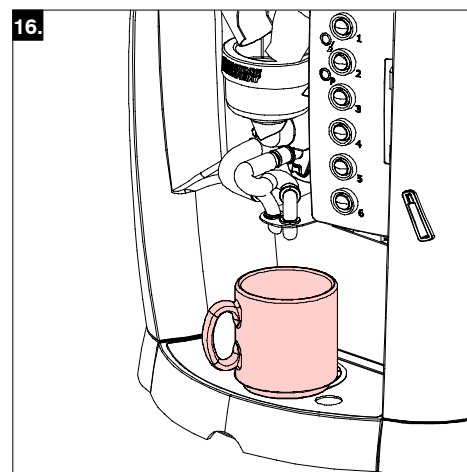
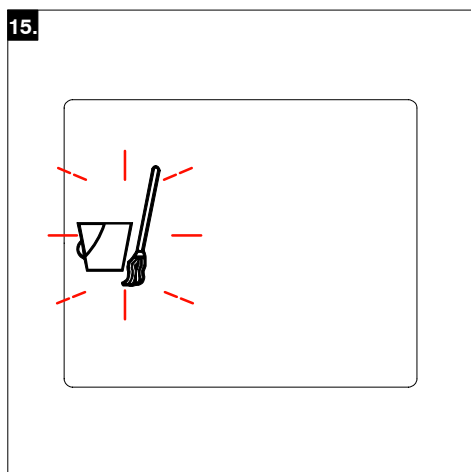
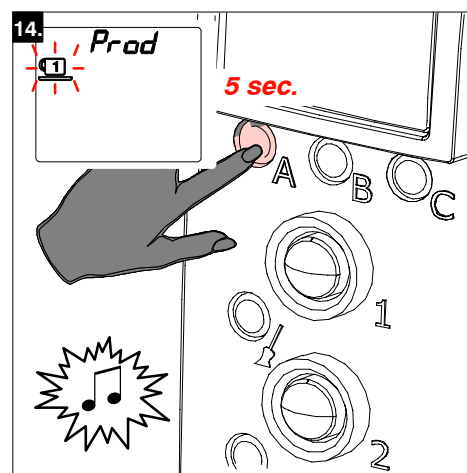
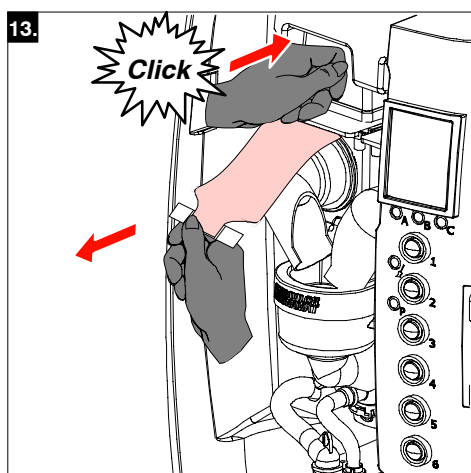
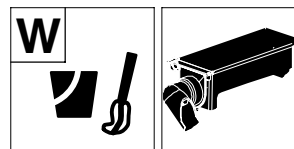

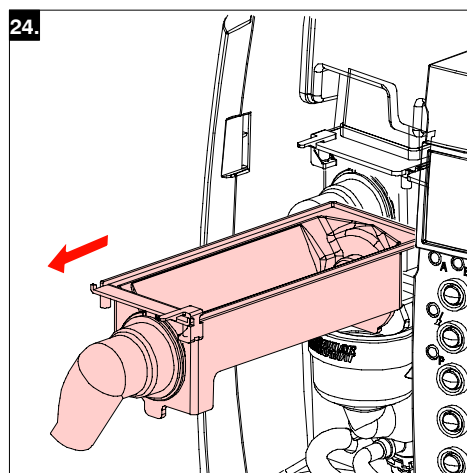
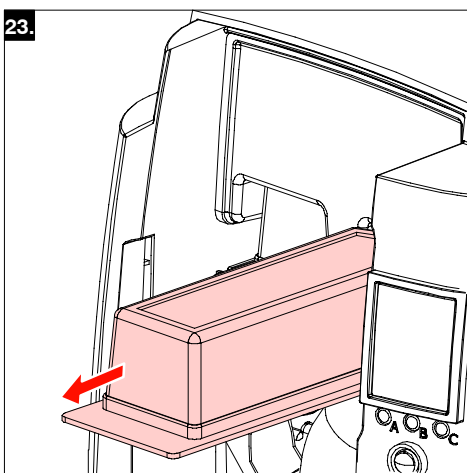
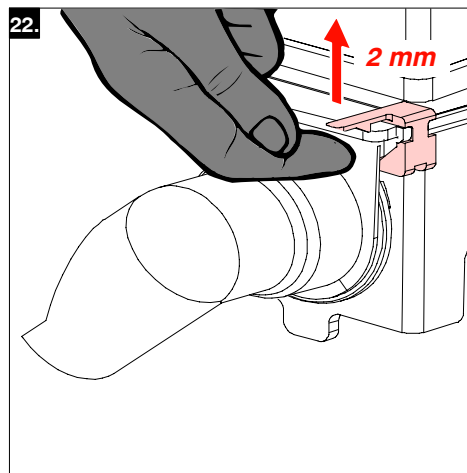
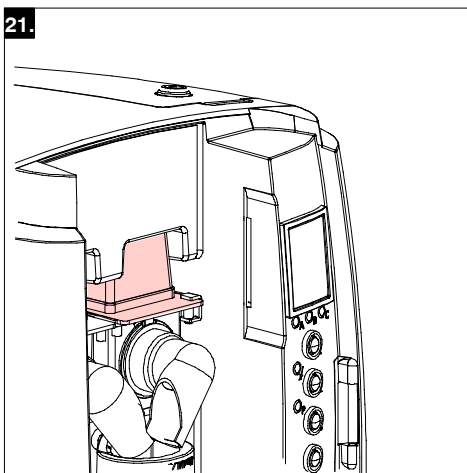
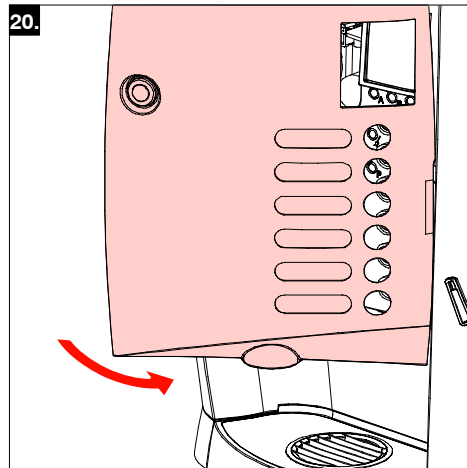
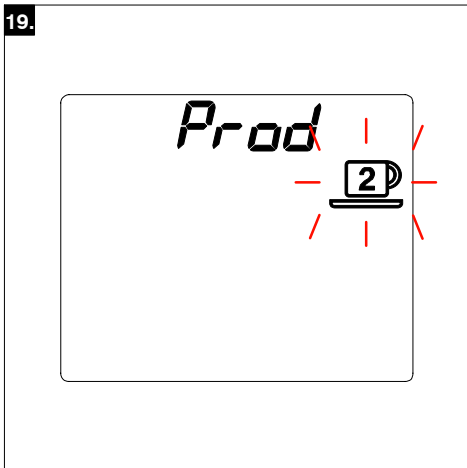
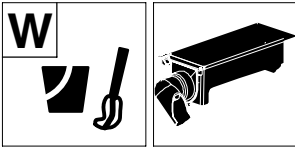

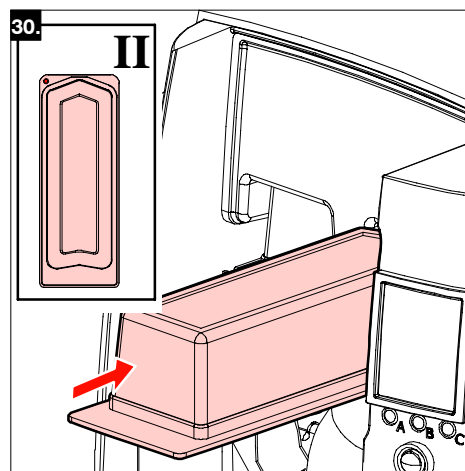
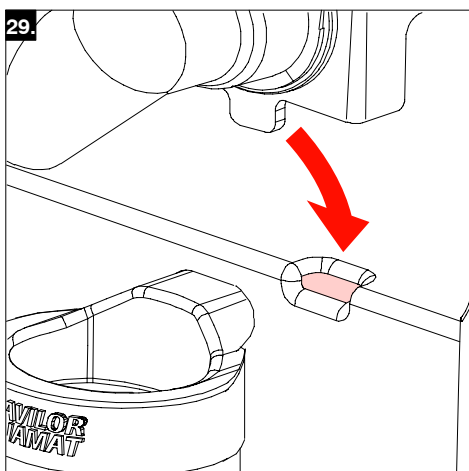
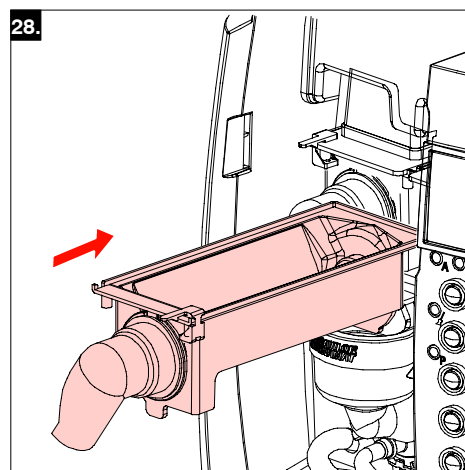
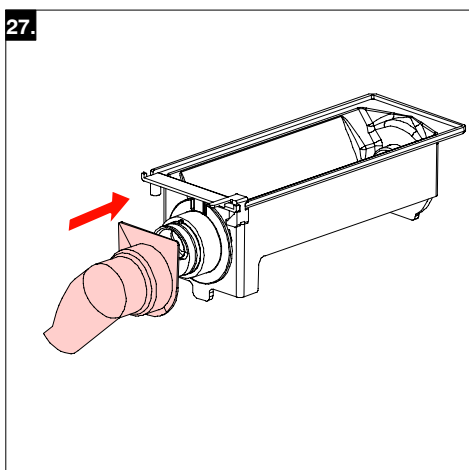
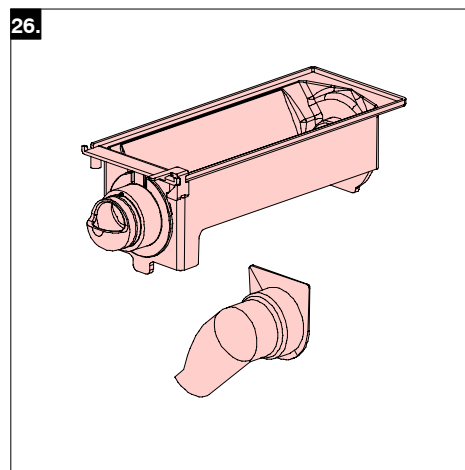
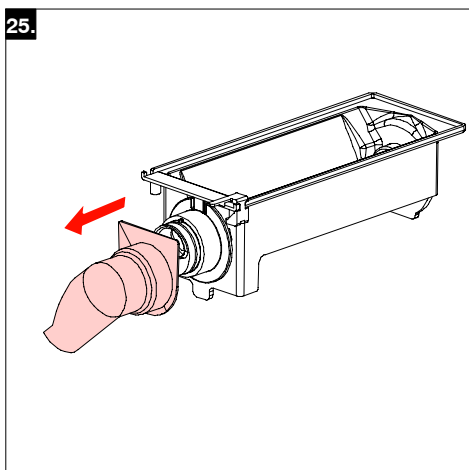
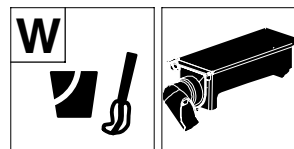

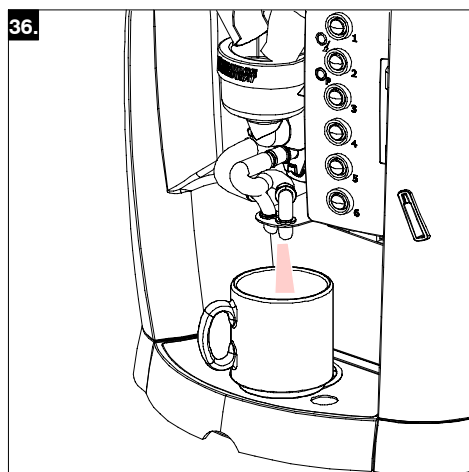
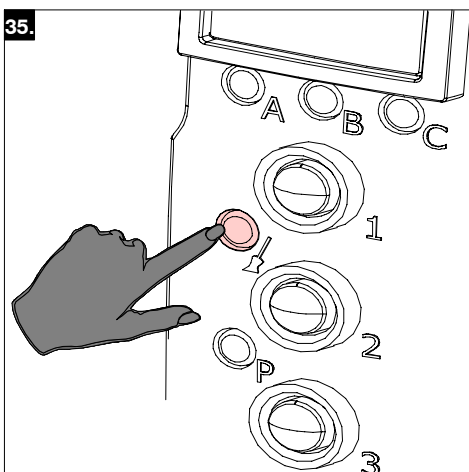
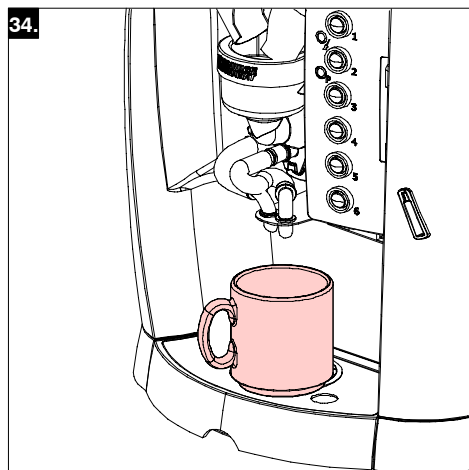
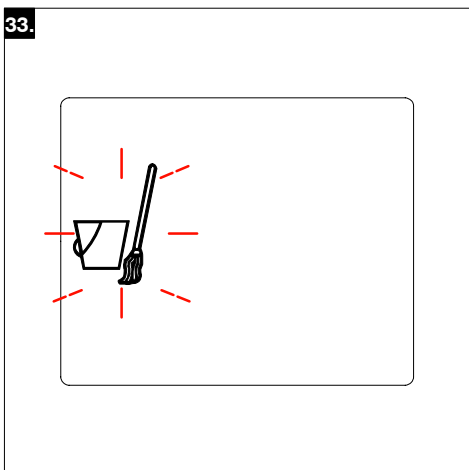
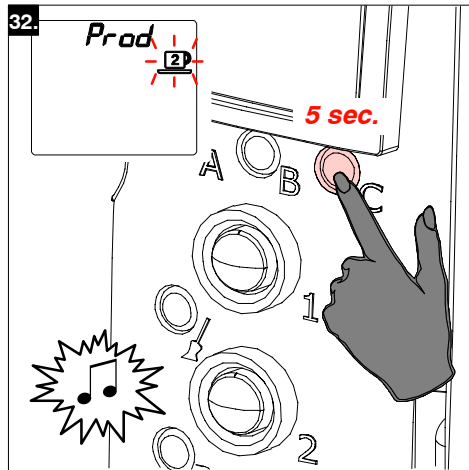
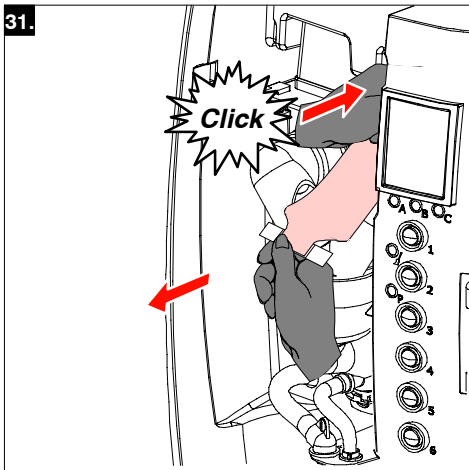
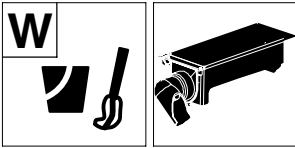

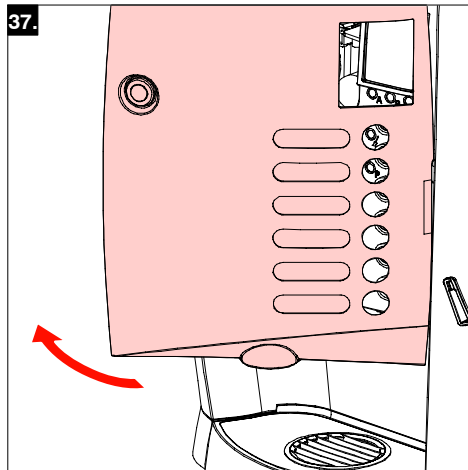
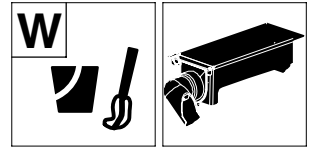

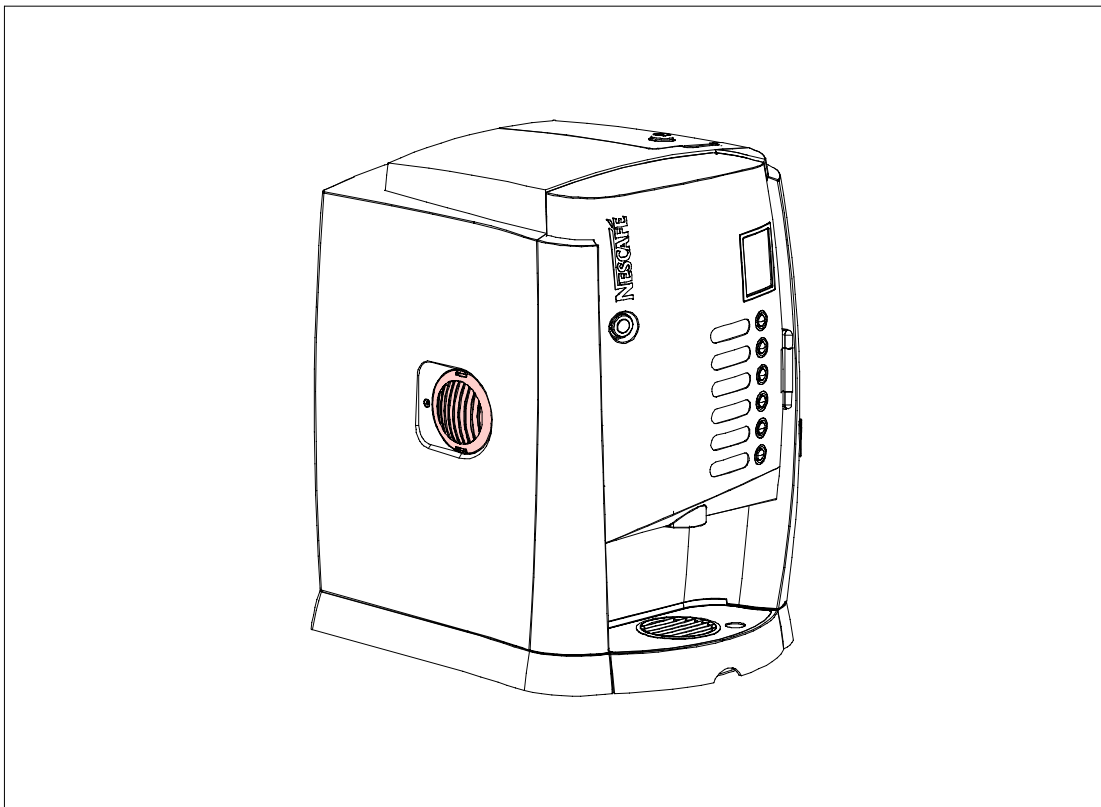
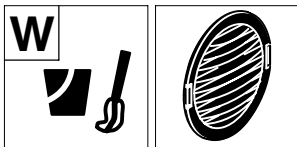

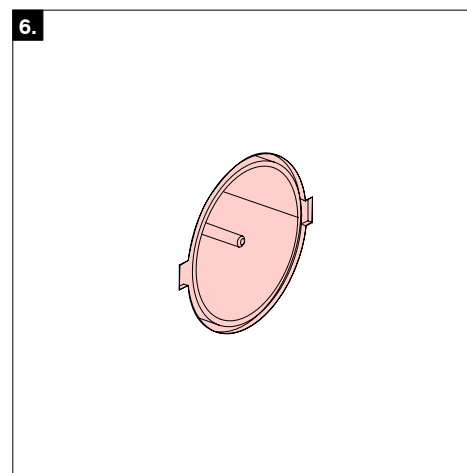
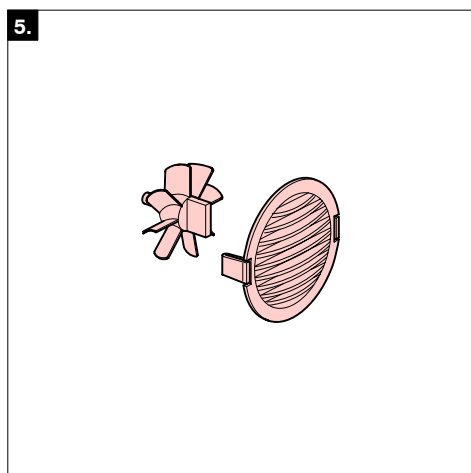
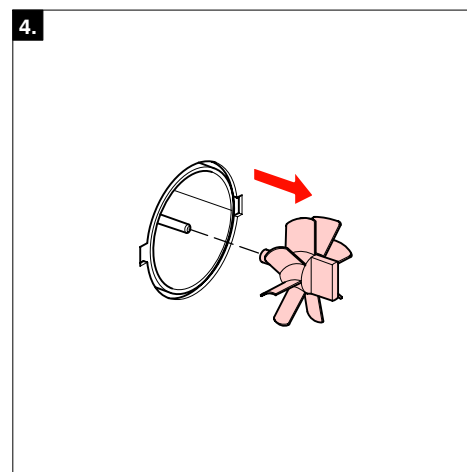
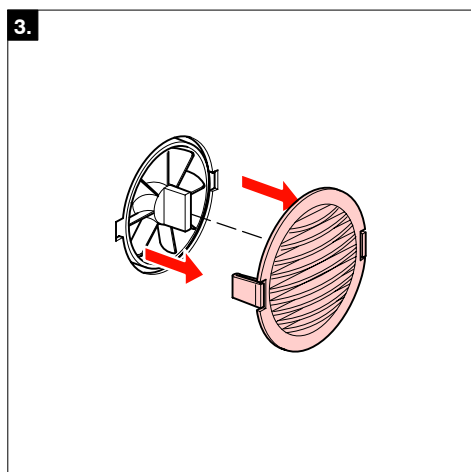
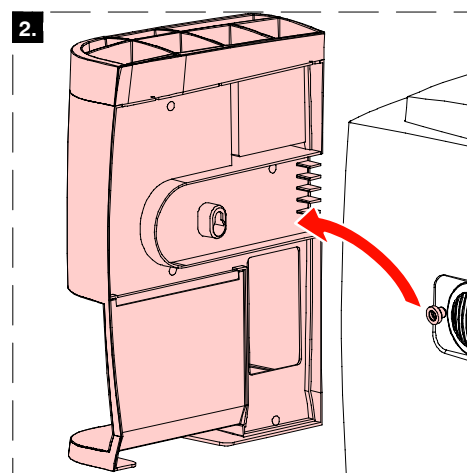
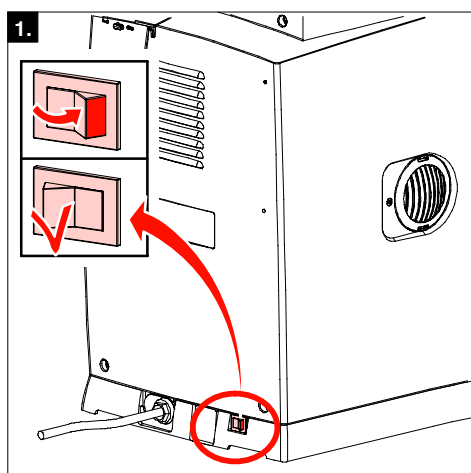
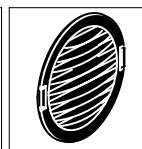
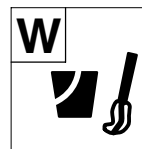

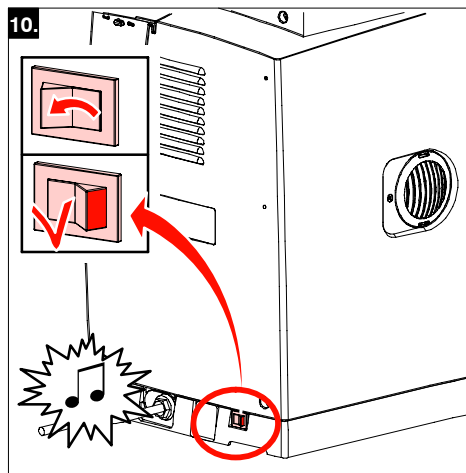
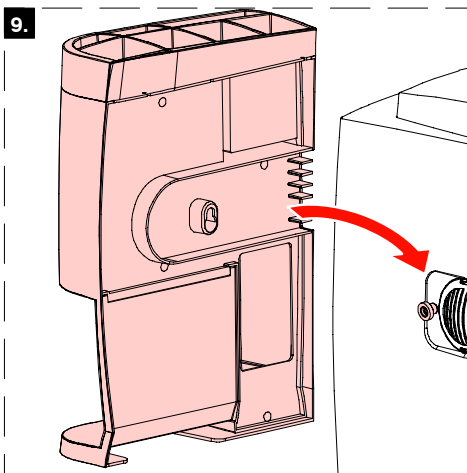
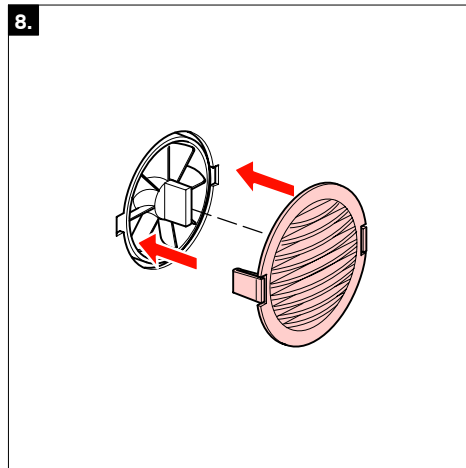
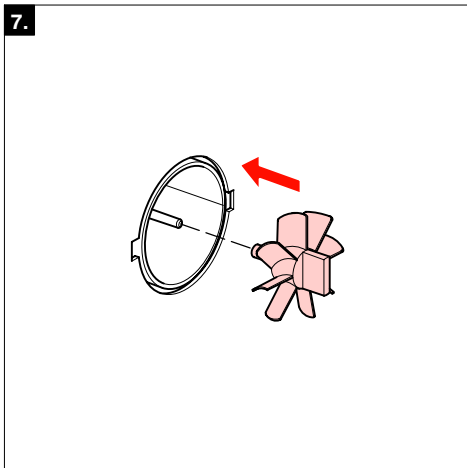
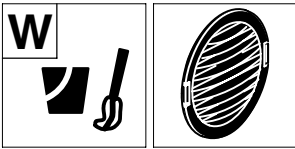

Messages
Messages
Meldungen
Meldingen
Meddelanden

Meldinger
Beskeder
Viestit
Mensajes
Mensagens

Messaggio
Μηνύματα
Zprávy
Wiadomości
Mesaje

Сообщения
Mesajlar
信息
メッセージ
메세지

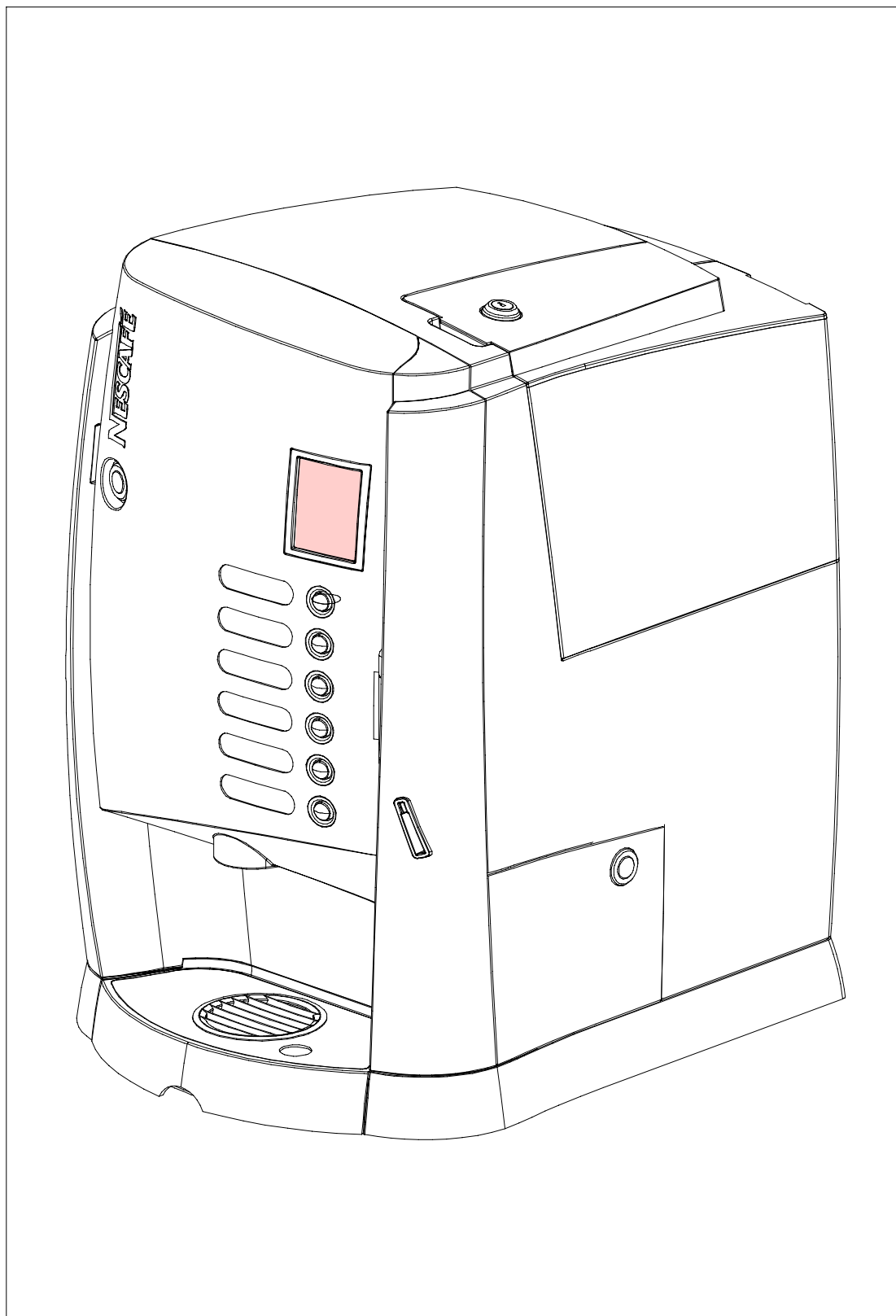

E

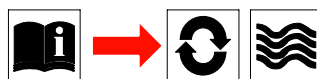
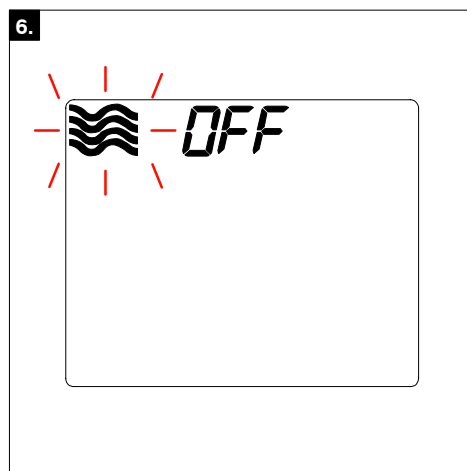
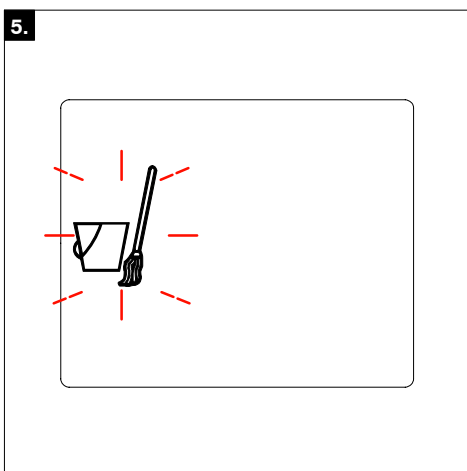
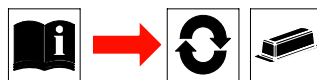
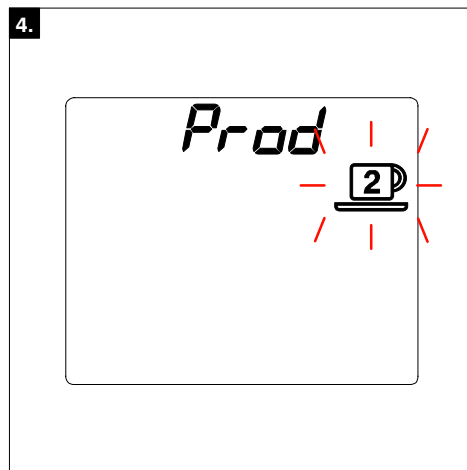
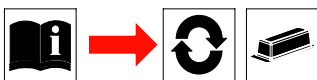
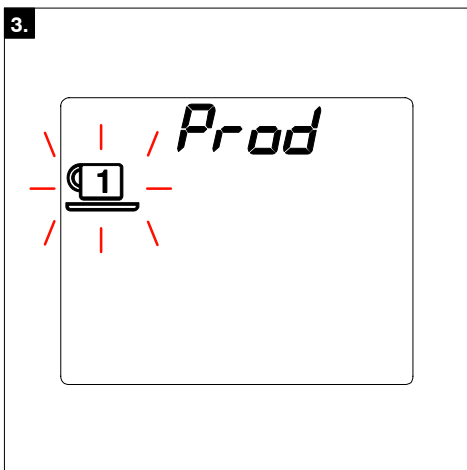
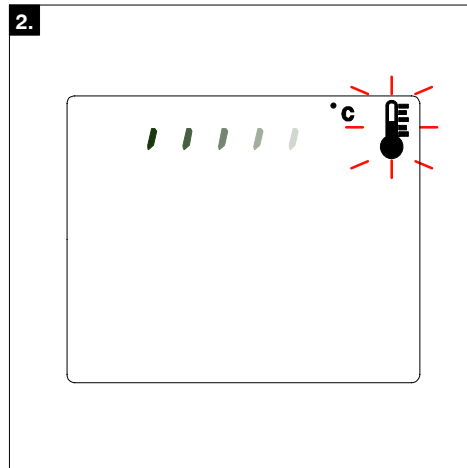
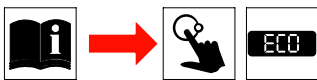
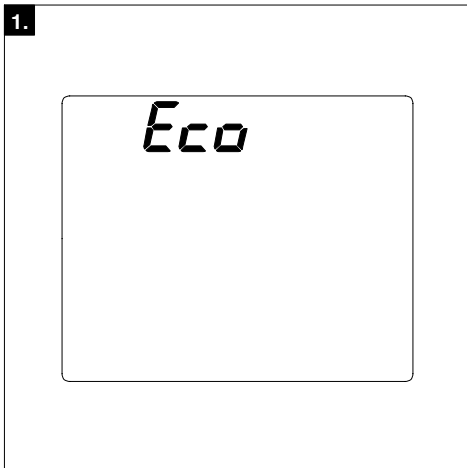

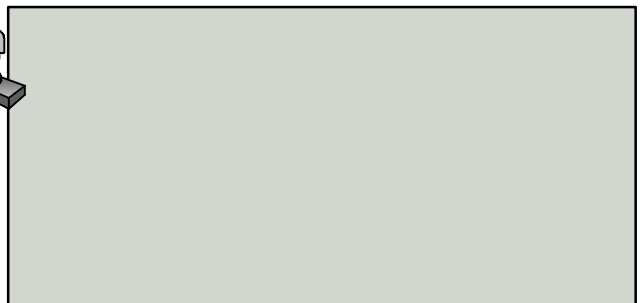
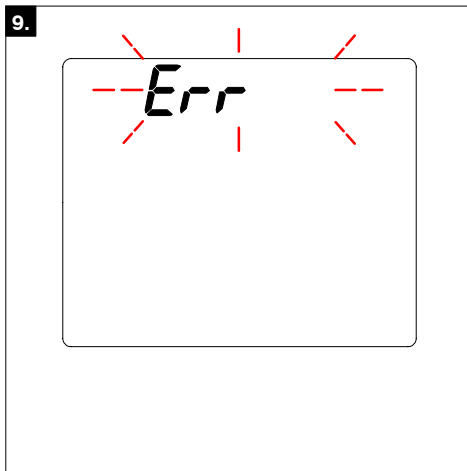
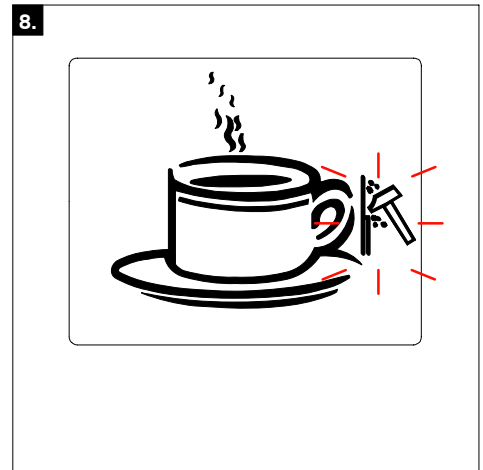
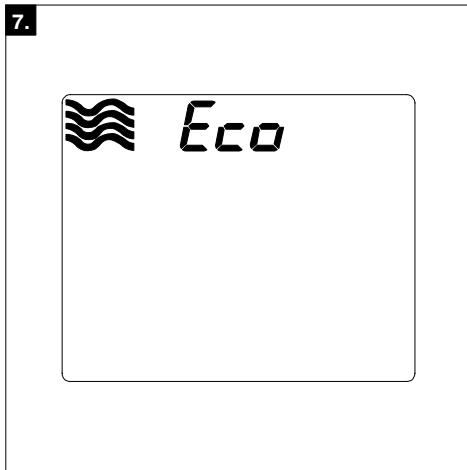



Italiano
Ελληνικά
Česky
Polski
Română

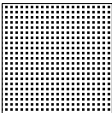

Русский
Türkçe
中文
日本語
한글

Prescrizioni di sicurezza
Έντυπο ασφαλείας
Bezpečnostní kniha
Wskazówki bezpieczeństwa
Carte instructaj



700.403.347

Инструкция по эксплуатации
Güvenlik kitabı
安全冊子
安全説明書
안전 지침서

Manuale di installazione e manutenzione
Οδηγίες εγκατάστασης και συντήρησης
Návod k instalaci a údržbe
Montaj i konserwacja
Manual de instalare si intretinere



700.403.459A

Установка и руководство по эксплуатации
Montaj ve Bakım Talimatı
設置與維修手冊
据付説明書 メンテナンスマニュアル
설치 및 보수 매뉴얼

Accessori
Εξαρτήματα
Příslušenství
Akcesoria
Accesorii

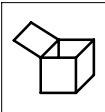

Аксессуары
Aksesuarlar
附件
備品
악세서리

Attendere
Αναμονή
Čekajte
Czekaj
Aşteaptă



Ждите
Bekle
等候
待つ
기다림

Penello
Βούρτσα
Kartáč
Szczołka
Perie



уистить щеткой
Fırçala
洗刷
ブラシ
붓

Panno umido
Υγρό πανί
Vlhká látka
Wilgotna szmatka
Cârpă umedă

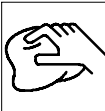

Влажная салфетка
Nemli bez
濕布
濡った布
젖은헝겂

Lavaggio
Ελαφριά πλύση
Vypláchnout
Płukanie
Clătire



Прополоскать
Durula
沖洗
すすぐ
세척

Detersivo
Απορρυπαντικό
Prostředek na odvrápnění
Środek myjący
Detergent



уистящее средство
Deterjan
去污劑
洗劑
세정제

Idoneo per lavastoviglie
Εγγυημένο για χρήση σε πλυντήριο πιάτων
Myčka –důkaz
Mycie w zmywarce
dozwolone
Spálätor veselä



Допускается Ристка в посудомоеРной машине
Bulaşık makinası uyumlu
可放於洗碗碟機清洗
食器洗い機で使用可能
접시세척기 사용금지

Risparmiatore energia
Εξοικονόμηση ενέργειας
Ochrona energie
Pogram "eco"
Mod economic



Накопитель энергии
Enerji tasarrufu
節省能源
省エネルギー
에너지 절약

Chiamare il fornitore
Καλέστε τον αντιπράσωπο / διανομέα
Volejte dodavatele
Teefon do dystrybutora
Cheamă distribuitorul



Позвоните дистрибьютору
Çağrı distribütörü
聯絡經銷商
販売店に連絡して下さい
전화 교환기

Decalcificazione
Αφαλάτωση
Odvápnění
Odkamienianie
Decalcarizare

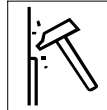

уистка от накипи
Kireçten arındırma
除垢
デスケール
스케일 청소

Opzione
Προαιρετικό
Nepovinný
Opcja
Opțional

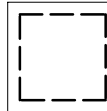

Необязательный
Opsiyonel
選擇
オプション
선택 사양



Italiano
Ελληνικά
Česky
Polski
Română

Русский
Türkçe
中文
日本語
한글

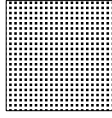

Informazione Πληροφορίες Informace Informacja Informație		Информация Bilgi 資料 情報 알림
Indice Περιεχόμενα Obsah Spis treści Index		Содержание İçindekiler 内容目録 目次 목차
Istruzione d'uso Χειρισμός Obsluha Instrukcja obsługi Instalare		Обслуживание Kullanım 操作 取り扱い 취급
Selezione pulsante Πλήκτρο επιλογής Volba tlačítek Przycisk selekcyjny Buton selectare		Выбрать напиток Seçim Düğmesi 選擇按鍵 選択ボタン 선택버튼
Riempire / scaricare Ενδειξη γεμάτο / Αδειο Plný / prázdny Pełny / pusty Plin / Gol		Наполнить / опорожнить Doldurma / Boşaltma 滿/空 給水・空にする 채움/탕비
Pulizia Καθαρισμός Čištění Czyszczenie Curățare		уистка Temizleme 清洗 洗淨 청소
Pulizia giornaliera Καθημερινή καθαριότητα Čištění, denné Czyszczenie, dzienne Curățare, zilnic		уистка ежедневно Temizlik, günlük 清洗・毎日 毎日の洗淨 일일 청소
Pulizia settimanale Εβδομαδιαία καθαριότητα Čištění, týdne Czyszczenie, tygodniowe Curățare, săptămânal		уистка раз в неделю Temizlik, haftalık 清洗・每週 每週の洗淨 주별 청소

Cartuccia Θήκη Zásobník Wkład Cartuş		Картридж Kartuş 咖啡卡芯 カートリッジ 카트리지
Contenitore prodotto Μεταλλικό δοχείο Zásobník Kanister Canistră		Канистра Kutu 罐子 ホッパー 케니스터
Acqua Νερό Voda Woda Apă		Вода Su 水 水 물
Miscelatore Σύστημα ανάμειξης Mísici system System mieszający Sistem amestecare		Смеситель Karışma sistemi 混合系統 攪拌システム 교반기
Sistema ventilazione Σύστημα εξαερισμού Odvzdušňovací system System chłodzenia Sistem ventilație		СИСТЕМА ВЕНТИЛЯЦИИ Navalandırma sistemi 通風系統 通氣システム 환풍기
Raccoglitocce Συλλέκτης σταγόνων Odkapni miska Ociekacz Colector picături		Каплексборник Damlama tepsi 接水盤 ドレンパン 물받이
Messaggio Μηνύματα Zprávy Wiadomości Mesaje		Сообщения Mesajlar 信息 メッセージ 메세지



**/// BRAVILOR
BONAMAT**

© 06-2006

700.403.458A